

# VIBRATIONS IN RECIPROCATING MACHINERY AND PIPING SYSTEMS

by

**J.C. Wachel**

**President**

**and**

**J. D. Tison**

**Senior Project Engineer**

**Engineering Dynamics Incorporated**

**San Antonio, Texas**

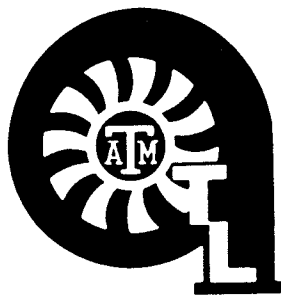

from

*Proceedings of 23rd Turbomachinery Symposium.*

Copyright 1994. All rights reserved. Reprinted with permission of  
the Turbomachinery Laboratory, Department of Mechanical Engineering,  
Texas A&M University, College Station, Texas 77840-3123.

# VIBRATIONS IN RECIPROCATING MACHINERY AND PIPING SYSTEMS

by

**J.C. Wachel**

President

and

**J. D. Tison**

Senior Project Engineer

Engineering Dynamics Incorporated

San Antonio, Texas



*J. C. "Buddy" Wachel is President of Engineering Dynamics Incorporated, an independent consulting firm. He has over 36 years of experience and has published over 40 technical papers. He has solved problems worldwide in piping vibrations, lateral and torsional critical speeds, rotor instabilities, and crankshaft failures. In addition to the practical field experience, he supervises the computer design audits of machinery and piping to ensure that the systems will have*

*acceptable vibrations and stresses. He has B.S.M.E. and M.S.M.E. degrees from the University of Texas. He is an ASME Fellow and a member of ASM. The Vibration Institute, and is a registered Professional Engineer in the State of Texas.*



*J. D. Tison is a Senior Project Engineer at Engineering Dynamics Incorporated. He has been extensively involved in field measurements and computer modelling of rotating and reciprocating equipment for over 16 years. For the past 10 years, his work has been primarily related to development and improvement of software for the simulation of pulsation in compressor and pump piping systems, along with overall responsibility for acoustic and mechanical design studies*

*of reciprocating compressor and pump piping systems. He is a member of ASME and holds Bachelors and Masters degrees (1975 and 1977) in Mechanical Engineering from the University of Florida.*

## ABSTRACT

A wide variety of vibration and failure problems occur in reciprocating machinery and piping systems. Excessive piping vibration problems usually occur when a mechanical natural frequency of the piping system or compressor manifold system is excited by a pulsation or mechanical excitation source. Since reciprocating compressors and pumps generate high pulsation levels at numerous harmonics, which in turn produce shaking forces, vibration and failure problems in these systems are common. Other problems, not associated with the piping, can be encountered with the compressor/engine frame foundation and anchoring systems. These can lead to failures of the bearings and crankshaft. In addition, special problems can occur due to the torsional natural frequencies and the high harmonic torques, due to the compressor loading.

Whenever high vibrations are encountered in reciprocating compressors, pumps and/or piping, it is necessary to determine if the vibrations and dynamic stresses are acceptable. Criteria to judge the acceptability of the vibrations are presented in this paper, along with troubleshooting methods to determine if the problems are caused by pulsation or mechanical resonances. The basic principles of pulsation generation and control are presented. The key to designing and operating safe piping systems is to control the pulsation levels and separate the mechanical natural frequencies from the pulsation excitation frequencies.

## INTRODUCTION

Vibrations in reciprocating machinery and piping are a major cause of fatigue failures, machinery downtime, leaks, high noise, fires, and explosions in refineries and petrochemical plants. Excessive piping or compressor manifold system vibration levels usually occur when a mechanical natural frequency is excited by a pulsation or mechanical excitation source. Since reciprocating machinery generates significant pulsation energy at numerous harmonics, serious vibration problems in reciprocating machinery systems are common.

Fatigue failures in reciprocating equipment piping systems generally involve lateral (beam type) vibration modes or compressor manifold system structural modes. Vibrations of the compressor/pump or engine frame, foundation, or skid can also influence the safety and reliability of the system. For example, excessive dynamic misalignment of the compressor/foundation system can cause bearing and crankshaft failures.

A basic summary of the various types of vibration problems encountered in reciprocating machinery installations is presented along with methods that can be used to evaluate and control these problems. The pulsation and mechanical excitation mechanisms and methods for their simulation in compressor and pump systems will be presented. Guidelines for designing compressor and pump piping installations to meet the applicable codes is presented.

Machinery vibration problems, such as those caused by torsional and lateral vibrations can be very important in the reliability of reciprocating machinery. These subjects are not covered, however, the important aspects of torsional vibrations were covered by Wachel and Szenasi [1].

## PIPING SPAN RESPONSES

The most common vibration problem encountered in a plant with reciprocating machinery is that of high piping vibration. The vast majority of the problems are caused by pulsation induced shaking forces at running speed and its harmonics. Typically, there is significant energy in many systems up to 20 times running speed. The piping layout and supports for reciprocating machinery piping systems should be designed such that

the piping mechanical natural frequencies are well above the frequencies of significant pulsation induced forces. This is opposite to the approach that is commonly taken in the design of centrifugal machinery piping where the dynamic shaking forces are low, the excitation forces are at high frequencies, and one of the major concerns is the equipment flange loading due to the thermal growth. Piping in reciprocating plants should have a minimum number of bends, and should be rigidly supported with optimized span lengths. Pipe hangers, weight supports, and guides are practically useless in the prevention of vibration when high pulsations are present in the piping.

The shaking force at every elbow in a piping span is proportional to the dynamic pressure and the inside area of the pipe. In typical plants, the pulsation amplitudes can exceed 10 percent of line pressure and the shaking forces can be significant. As a basic rule of thumb, piping vibrations can usually be controlled with normal good engineering practices with regard to clamps and supports if the pulsation induced shaking forces are less than 500 lb (peak-to-peak) in ground level piping, and 200 lb (peak-to-peak) for elevated piping, such as in pipe racks, offshore platforms, etc. Since the shaking force is proportional to the pressure pulsation amplitude and the projected flow area of the pipe, pulsation levels must be controlled to achieve acceptable vibrations.

Vibration-induced failures in piping systems often result from the excitation of a mechanical natural frequency of an individual piping span. To solve this problem, the mechanical natural frequency can be placed above the excitation frequency by reducing the span length, while providing ample support stiffness. In the design process, to ensure that piping systems are free from excessive vibrations, it is possible to make the individual piping spans nonresonant to pulsation and mechanical excitation frequencies generated by reciprocating compressors and pumps. To accomplish this, it is important to be able to calculate the mechanical natural frequencies of individual piping spans. Simplified design procedures have been published [2] that can be used to calculate the mechanical natural frequencies of common piping configurations. For complex systems, finite element computer programs are used to evaluate piping system natural frequencies. A summary of the techniques for calculating the natural frequencies of straight piping spans and spans with elbows is presented, which can be used to detune resonant piping spans or to design nonresonant vibration-free piping systems. The piping span natural frequencies can be approximated using distributed uniform beam vibration theory. Configurations that exist in typical plant piping have boundary conditions that differ from ideal values; however, the deviation is generally not large.

The natural frequency of any piping span can be calculated if the frequency factor, span length, diameter, wall thickness and the weight per length are known. For a straight uniform piping span, the natural frequency can be calculated using the following relationship:

$$f_o = \frac{\lambda}{2\pi} \sqrt{\frac{gEI}{\mu l^4}} \tag{1}$$

where:

- $f_o$  = Span natural frequency, Hz
- $g$  = Gravitation constant, 386 in/sec<sup>2</sup>
- $E$  = Modulus of elasticity, psi
- $I$  = Moment of inertia, in<sup>4</sup>
- $l$  = Span length, in
- $\lambda$  = Frequency factor, dimensionless

$\mu$  = Weight per unit length of beam (including fluid and insulation), lbs/in (Equal to  $\rho A$  if the weight of fluid and insulation is negligible).

$\rho$  = Density, lbs/in<sup>3</sup>

$A$  = Pipe cross-sectional area, in<sup>2</sup>

By substituting in material properties for steel,  $E = 30 \times 10^6$  lb/in<sup>2</sup>,  $\rho = 0.283$  lb/in<sup>3</sup>, and  $g = 386$  in/sec<sup>2</sup>, equation 1 can be simplified to:

$$f_o = 223\lambda \frac{k}{L^2} \tag{2}$$









where:

$k$  = radius of gyration, in

$L$  = length of span, ft

Note that this equation does not include the weight of the fluid and the insulation. The effect of fluid and insulation can be considered by multiplying the calculated natural frequency by the square root ratio of the weight of the pipe divided by the total weight per foot of the pipe, plus the fluid and the insulation. The frequency factors ( $\lambda$ ) for calculating the first two natural frequencies for ideal straight piping spans are given in Figure 1. The mode shapes associated with common span configurations are illustrated in Figure 2.

The natural frequencies of selected pipe configurations with piping elbows (L-bends, U-bends, Z-bends, and three dimensional bends) were analyzed using a finite element program

Piping Configuration	Frequency Factor		Deflection Stress* Factor		Velocity Stress* Factor		
	1st	2nd	1st	2nd	1st	2nd	
	3.52	22.4	366	2295	219	219	
	9.87	39.5	1028	4112	219	219	
	15.4	50.0	2128	6884	290	290	
	22.4	61.7	2935	8534	275	290	
	L-Bend Out	16.5	67.6	1889	9690	241	301
	L-Bend In	59.4	75.5	7798	9575	276	266
	U-Bend Out	18.7	35.6	2794	4628	314	273
	U-Bend In	23.7	95.8	3751	8722	332	191
	Z-Bend Out	23.4	34.2	3522	4133	317	254
	Z-Bend In	22.4	96.8	3524	8933	331	194
	J-D Bend	20.6	27.8	3987	4752	407	359
Formula	$f = \frac{\lambda}{2\pi} \sqrt{\frac{gEI}{\mu l^4}}$		$S = K_{xy} \frac{P}{t^2} SCF$		$S = K_v V SCF$		
Reference	Eq. 1		Eq. 10		Eq. 13		

\*Steel Piping ( $E = 30 \times 10^6$  psi,  $\rho = 0.283$  lb/in<sup>3</sup>)

Figure 1. Frequency and Stress Factors for Idealized Piping Spans.

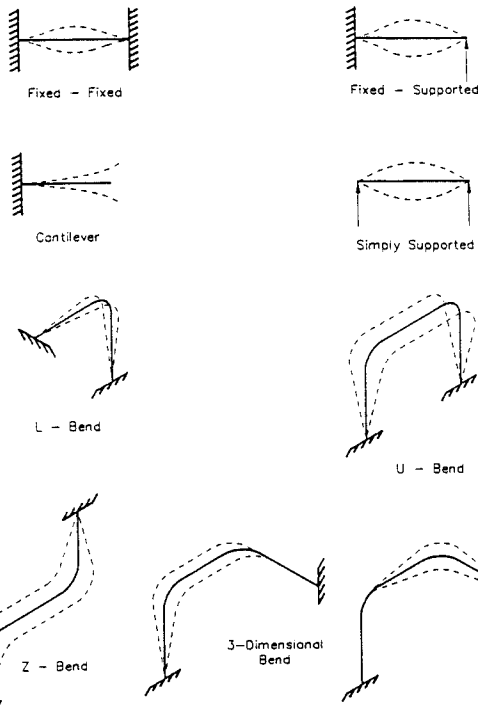

Figure 2. Vibration Mode Shapes of Common Span Configuration.

(ANSYS) to generate frequency factors for the first two modes [2]. The frequency factors were published for a range of aspect ratios to develop sufficient information so that the natural frequency of piping spans could be approximated for most common configurations. The frequency factors for the first two modes of vibration of a L-bend as a function of the aspect ratio of the leg lengths and the total length of the span are given in Figure 3. Frequency factors for the U-bend, Z-bend, and three dimensional bends can be found in Wachel, et al. [2].

To calculate the first natural frequency of a piping span with a concentrated weight, the following equation can be used.

$$f_p = \frac{f_o}{\sqrt{1 + \alpha \frac{P}{W}}} \tag{3}$$

where:

$f_p$  = Pipe span natural frequency with concentrated weight, Hz  
 $f_o$  = Pipe span natural frequency without concentrated weight, Hz

P = Concentrated weight, lb

W = Weight of beam span, lb

$\alpha$  = Weight correction factor, dimensionless

Weight correction factors for use in calculating the natural frequencies of ideal piping spans for weights at the maximum deflection locations are given in Figure 4. If two weights are located in one span, Dunkerly's equation can be used to calculate the effect of the second weight [3].

Piping Configuration	Weight Location	Weight Correction Factor $\alpha$	
Cantilever	L	3.9	
	3L/4	1.7	
Simply Supported	L/2	2.0	
	L/4	1.1	
Fixed-Supported	L/2	2.3	
	3L/4	1.6	
Fixed End	L/2	2.7	
	L/4	0.9	
L-Bend	First Mode Out-of-Plane	B/A = 0.5	B/A = 1.0
		A/2	1.24
	A	2.69	2.25
		B/2	0.39
U-Bend	First Mode B/A = 1.0	Out	In
		A/2	0.26
	A	2.24	1.79
	B/2	2.31	2.00
Z-Bend	First Mode B/A = 1.0	Out	In
		A/2	0.40
	A	2.76	1.77
	B/2	2.21	2.09
3D-Bend	First Mode B/A = 1.0	1st	2nd
		A/2	0.31
	A	2.35	1.58
	B/2	2.06	2.77

Figure 4. Weight Correction Factors for Uniform Piping Configurations.

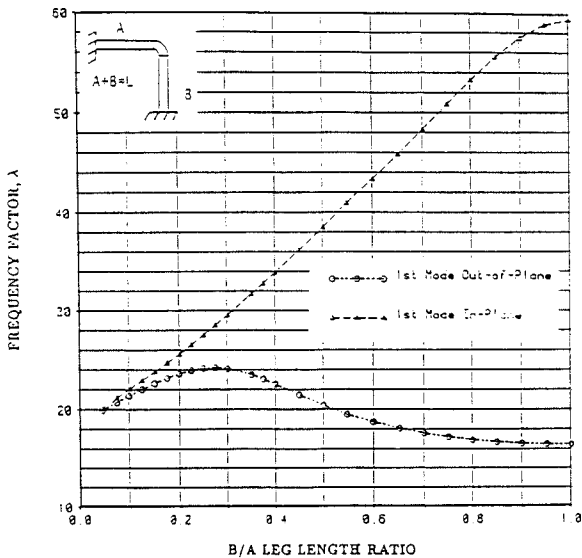

Figure 3. Frequency Factors for Uniform L-Bend Piping Configuration.

Theoretical beam natural frequency calculations can be corrected to make them agree more closely with measured field data using the correction factors tabulated by Wachel [4]. The use of these correction factors will normally give answers that are within 15 percent of measured values. For the majority of piping vibration problems, this accuracy should be sufficient. The procedures for calculating the natural frequency of piping spans can be used to select clamp spacings, which ensure that the piping spans will be resonant above some selected frequency. Support spacing vs the corresponding natural frequency for straight runs of pipe is given in Figure 5.

Evaluation of the Severity of Piping Span Responses

When high piping vibration levels are experienced in an installation, the vibration analyst/engineer must determine wheth-

Recommended Maximum Clamp Spacing (ft) Based on Natural Frequency of Simply-Supported Span											
Natural Freq. (Hz)	Nominal Pipe Size/Outside Diameter (in)										
	2	4	6	8	10	12	14	16	18	20	24
5	18.9	25.0	31.3	35.9	40.1	43.7	45.8	48.9	51.9	54.7	
10	13.3	18.4	22.3	25.4	28.4	30.9	32.4	34.6	36.7	38.7	
15	10.9	15.0	18.2	20.7	23.2	25.2	26.4	28.3	30.0	31.6	
20	9.4	13.0	15.7	18.0	20.1	21.8	22.9	24.5	26.0	27.4	
25	8.4	11.6	14.1	16.1	17.9	19.5	20.5	21.9	23.2	24.5	
30	7.7	10.6	12.9	14.7	16.4	17.8	18.7	20.0	21.2	22.3	
35	7.1	9.8	11.9	13.6	15.2	16.5	17.3	18.5	19.6	20.7	
40	6.7	9.2	11.1	12.7	14.2	15.4	16.2	17.3	18.4	19.3	
45	6.3	8.7	10.5	12.0	13.4	14.6	15.3	16.3	17.3	18.2	
50	6.0	8.2	10.0	11.4	12.7	13.8	14.5	15.5	16.4	17.3	
55	5.7	7.8	9.5	10.8	12.1	13.2	13.8	14.8	15.6	16.5	
60	5.4	7.5	9.1	10.4	11.6	12.6	13.2	14.1	15.0	15.8	
65	5.2	7.2	8.7	10.0	11.1	12.1	12.7	13.6	14.4	15.2	
70	5.0	6.9	8.4	9.6	10.7	11.7	12.2	13.1	13.9	14.6	
75	4.9	6.7	8.1	9.3	10.4	11.3	11.8	12.6	13.4	14.1	
80	4.7	6.5	7.9	9.0	10.0	10.9	11.4	12.2	13.0	13.7	
85	4.6	6.3	7.6	8.7	9.7	10.6	11.1	11.9	12.6	13.3	
90	4.4	6.1	7.4	8.5	9.5	10.3	10.8	11.5	12.2	12.9	
95	4.3	6.0	7.2	8.2	9.2	10.0	10.5	11.2	11.9	12.6	
100	4.2	5.8	7.0	8.0	9.0	9.8	10.2	10.9	11.6	12.2	

Figure 5. Table of Natural Frequencies Vs Pipe Span (ft).

er or not the high vibrations represent a problem. The evaluation is based primarily on the vibratory stresses introduced into the piping. In some cases, seemingly high vibrations may not cause excessive stresses in the piping, but may require correction because of the adverse psychological effect it can have on personnel.

The vibrations are obviously too high if there has been a piping fatigue failure. Ten million cycles of stress levels in excess of the endurance limit will cause a fatigue failure. To illustrate this point, excessive vibrations at 5.0 Hz require approximately 20 days to reach ten million cycles; therefore, for low frequency vibrations, failures may not occur for almost a month. If the vibrations are at 100 Hz, it would require approximately one day of operation at the excessive levels. This means that extreme care should be exercised in evaluating piping systems in low speed reciprocating machinery systems or any system which has low frequency vibrations.

Vibration levels are sensitive to engine speed and loading conditions, therefore, the vibrations that are present during an initial survey may not be the highest that will occur. The location of maximum vibration is sometimes difficult to establish in an initial survey. If the high vibration levels have been occurring for many months without failures, the vibrations may not be so severe that failure is imminent, but may need to be reduced to increase the margin of safety.

In order to assist the analyst in the troubleshooting process, the diagnostic charts given in Figures 6, 7, 8, 9, 10, and 11 define step-by-step procedures to guide the analyst/engineer through a logical approach in troubleshooting a piping vibration problem [5]. The charts suggest particular data to be taken, specific questions to be asked, and provide a path to be taken, depending upon the type of vibration problem. By following these steps, along with the simplified analyses presented in the text, the analyst/engineer should be able to define the probable sources of the vibration problem. Note that for reciprocating equipment, vibration problems are normally in the low frequency (<300 Hz) range.

*Review the Operating History and Vibration Data*

The analyst should review the past history of the vibration problem to try to correlate operating conditions to the incident of high vibrations or failures. Review any background design analyses reports that may give clues as to the excitation sources in the system. For example, if a compressor system has been designed according to API 618 [6], there should be a report showing predicted pulsation levels and design guidelines for the mechanical layout and support of the piping. Since most high vibration or failure problems involve a mechanical or pulsation resonance, analyze any vibration data for frequency content. It

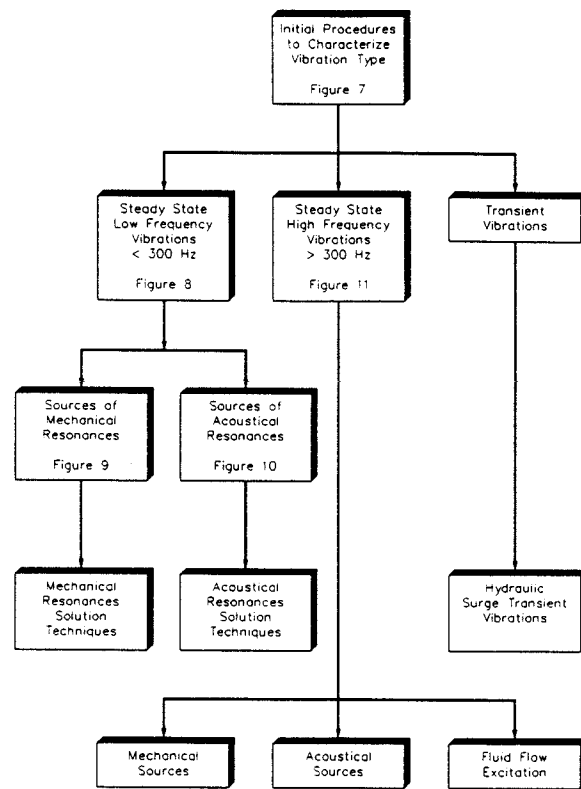

Figure 6. Master Flowchart for Vibration Diagnostics.

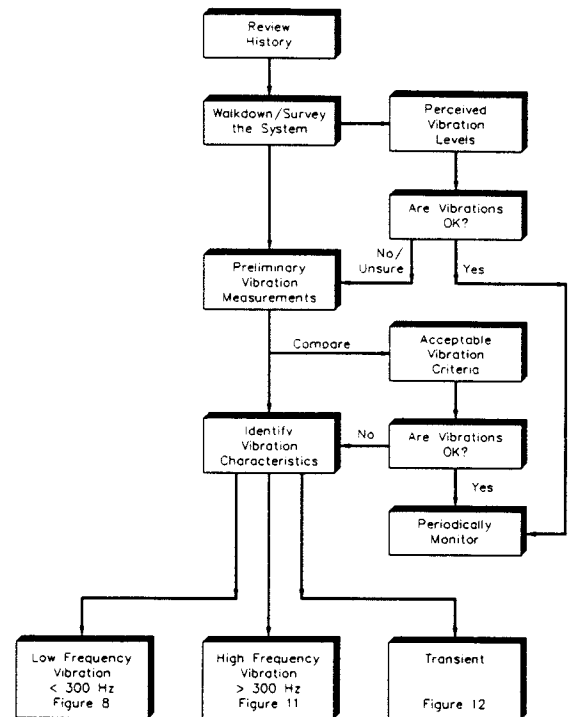

Figure 7. Flowchart Procedures for Identifying Overall Vibration Characteristics.

is important to investigate the problem at the particular operating conditions that result in the highest amplitudes.

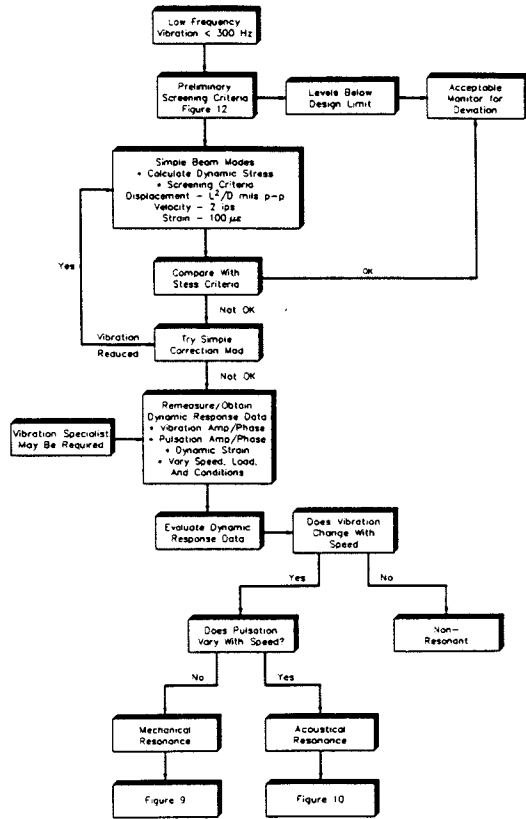

Figure 8. Flowchart for Investigating Low Frequency Vibration Problems.

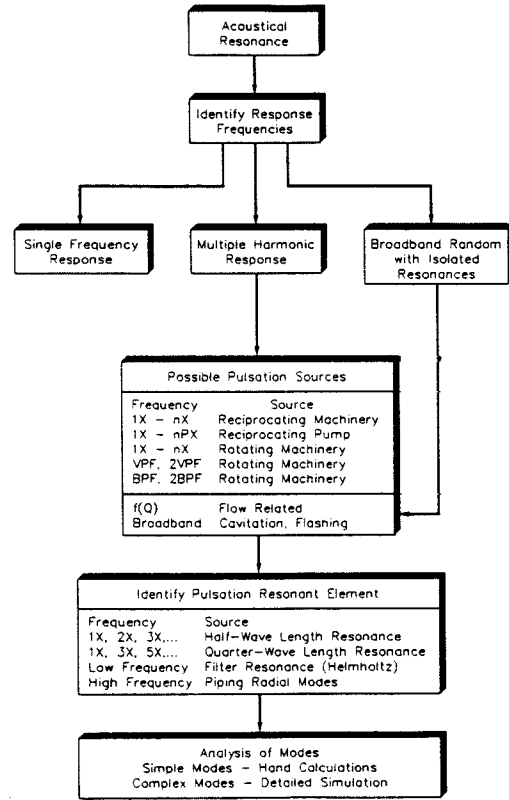

Figure 10. Flowchart for Determination of Excitation Source of Acoustical Resonances.

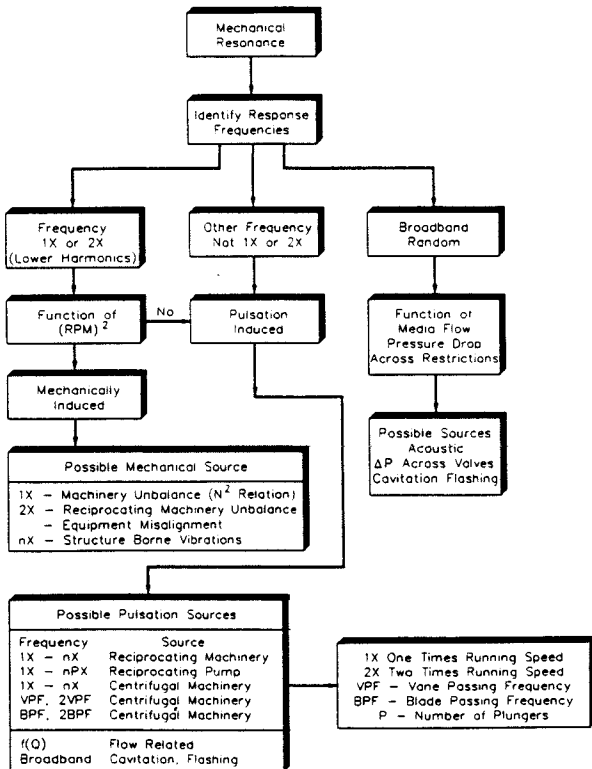

Figure 9. Flowchart for Determination of Excitation Source of Mechanical Resonances.

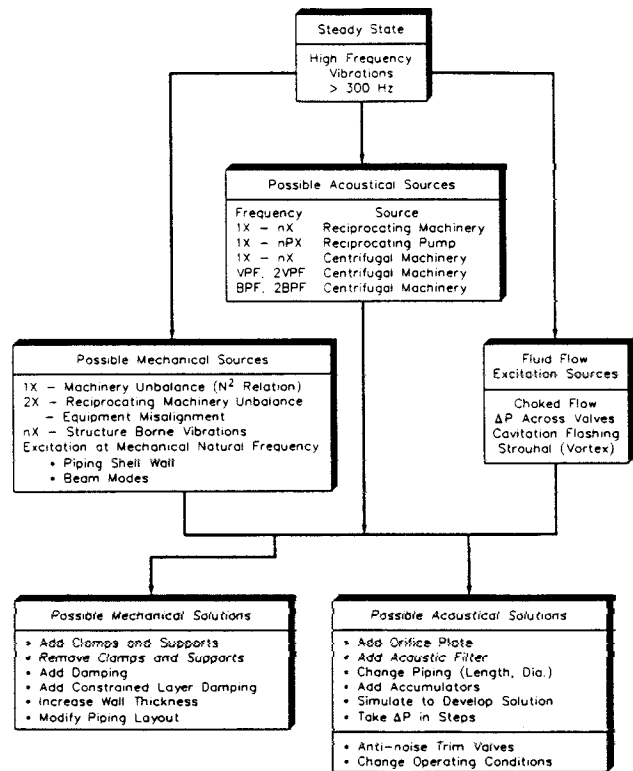

Figure 11. Flowchart for Investigating High Frequency Vibration Problems.

### *Walkdown/Survey the System*

The first step in the determination of the severity of the vibration problem is to make an initial survey or walkdown of the piping system. The purpose of the walkdown is to determine if the reported high vibrations are a real problem or not. During the walkdown, watch for the following common symptoms of piping vibrations which indicate potential problems.

**Failed Piping with Fatigue Cracks.** If a pipe fails and the failure surface has classical fatigue markings, an obvious vibration problem exists. Fatigue failures occur most often at points of high stress concentration, such as at branch connections and welded joints. Other likely points would be near supports or restraints.

If failures occur repeatedly near the same location in the piping system, this is normally an indication that there is a mechanical or acoustical resonance, or both. If there are no resonances present, there must be an excessive excitation force in the system. The fatigue failure surface should be carefully examined since the direction of the crack can give clues to the mode shape of the vibrations. The location and orientation of the failure should be fully documented with photographs or sketches, so that if it is necessary to perform tests, strain gages can be placed in the appropriate locations.

For example, if the fatigue failure occurred as a circumferential crack, the failure was probably caused by a bending mode. If the fatigue crack occurred on a 45 degree spiral, the failure may have been caused by a torsional mode, such as the low mode of vibration of the compressor manifold system. Cracks in the longitudinal direction could be a result of a high frequency shell wall resonance.

If the failure occurred at the piping reinforcement weld, the quality of the weld may be at fault. The location of a fatigue crack along the weld line usually indicates a high stress concentration factor. The stress concentration factor for a good weld can be as low as 1.6; however, for a poor weld, the stress concentration factor can be five or greater. Other locations of high stress concentration include all weld joints, restraints, hangers, and other geometrical discontinuities, such as changes in piping wall thicknesses.

Since the function of the piping system is to contain the fluid, bolt failures which cause a leak in flanges, or at valves, etc., are considered to constitute a failure of the piping system. Therefore, check the bolted joints in the piping system to ensure that they are not loose and have no failures. This is very critical on high pressure letdown valves that may have sonic flow. Often the high level turbulence will excite the lateral and axial modes of the piping and cause bolt failures.

**Visual Vibrations/Line Movements.** During the initial survey, look for parts of the piping system that are obviously vibrating excessively. Tests have shown that, with training, a person can judge the approximate amplitude and can distinguish low frequency from high frequency vibrations, usually those less than 50 Hz. This judgement is enhanced when the sense of feeling is used, such as feeling the vibrations with a coin held in the fingers. (Use the coin to touch the pipe, since the pipe may be hot!) If the piping is experiencing high vibrations or movements, then the approximate location of the maximum vibrations should be noted, so that vibration measurements can be made at that location when detailed testing is performed. Many times individual components, such as gauge lines, pressure gauges, thermowells, instrument lines, etc., will vibrate and result in failures. Particular attention should, therefore, be paid to these small connections and other appurtenances during this initial survey. It is best to combine physical senses with a handheld vibration data collector, if it is available.

In liquid piping systems, low frequency movements of the pipe may indicate waterhammer. This can be caused by sudden opening or closing of a valve, which may produce a pressure wave that moves down the pipe. As it reaches elbows or other changes in direction or cross section, a large low frequency force can shock the pipe and cause large motion.

Careful attention should be paid to determine if the vibrations are steady state or transient in nature. Also, note whether the vibrations may have a varying amplitude or "beating," which is typical of a piping vibration in which excitation is occurring from two sources at slightly different frequencies.

**Damaged or Ineffective Supports and Restraints.** During the initial survey, careful attention should be paid to the condition of supports and restraints, and particularly the bolts. Loose restraints, supports, clamps, or bolts that have been bent or broken can lower the resonant frequencies of piping and cause the mechanical natural frequency to occur at a frequency of high amplitude excitation. Loose or broken supports/restraints can be a result of resonant vibrations, high dynamic shaking forces, inadequate design, or excessive thermal loads. If the support does not have sufficient stiffness to control the static and dynamic loads, it may bend due to the large forces and movements. For example, U-bolt clamps have very little stiffness and are ineffective restraints and, in piping systems with large shaking forces, they will often fail or lose their preload. Thermal pipe guides should be investigated since they are designed to keep the pipe in position in a particular direction, but still may not provide adequate vibration control. Long unsupported spans with low support stiffness could result in low mechanical natural frequencies. Piping spans with unsupported block valves or other heavy masses can also have low response frequencies.

Note where the maximum vibrations occur and determine the nearest effective support location. The lowest lateral natural frequency of a span between supports is an inverse function of the square of the span length. The stiffness of a piping span is a function of the span length between supports cubed. Moving the supports closer together will shift the natural frequency and increase the stiffness and may significantly reduce the vibrations for those systems with low frequencies of less than 300 Hz. Determine possible locations for restraints that could be added to detune the resonant frequency.

In systems that experience transient vibrations, the supports or snubbers may have to be checked to ensure that they are behaving in the proper manner. This is particularly important if large displacements at the snubbers and supports have been experienced.

**High Vibration of Appurtenances.** Many failures that occur in piping systems are of the smaller diameter piping connected to the larger piping. Vents, drains, pressure gauge lines, instrument lines, thermowells, etc., are most sensitive to this kind of failures. The vibrations of the appurtenance can be caused by a base excitation, whereby direct mechanical coupling between the vibrating pipe or machinery causes the side branch to vibrate at its mechanical natural frequency. Therefore, all appurtenances near points of high vibrations should be examined. The large pipe can be excited by pulsations or by machinery unbalance. Examples of the mechanical coupling between a pump and its piping which caused vent and drain valve failures are discussed by Olson [7].

Failures of appurtenances can also occur in high energy fluid flow systems near valves with high pressure drops, especially if the flow is sonic. The high turbulent energy can excite the low frequency natural frequencies, and can also excite the shell wall resonances in the axial and circumferential directions of the larger diameter piping. These shell wall resonances can cause excessive stresses at points of high stress concentration.

If high vibrations occur at a particular location, note where the closest point of coupling occurs. Points of acoustic coupling include the closed end of headers, pulsation bottles, restrictions in the piping such as partially closed valves, orifices, piping elbows, and any changes in piping cross section. A branch pipe from the suction and discharge lines to a closed bypass valve may be the point of coupling for machinery piping systems. Blind ends of headers, tees, and manifolds most often serve as points of acoustic coupling.

*High Impact or Flow Excited Noise.* During the initial walk-down survey, listen for impact noises that may be created by the piping vibrating and impacting loose clamps and supports. The type of noise created due to the vibration will give clues as to the nature of the vibrations. If the noise is a pure tone with a constant amplitude, the vibrations will most likely be steady state and caused by a constant amplitude shaking force at or near a mechanical natural frequency. If the noise is broadband and varies in amplitude, or is intermittent, the vibrations may be caused by high flow excitation or a result of some process transient.

In piping systems with high flow velocities, such as systems with pressure letdown valves, bypass lines, flare lines or fluid transfer lines, the major indication of a potential vibration problem is the presence of high noise levels. The high energy broadband noise created by a large pressure drop across a letdown valve may be amplified by mechanical shell wall resonances. If acoustical resonant natural frequencies are present in the range of the broadband energy, they will be excited and the noise spectra will be influenced by these resonances.

In addition to the broadband energy created by the flow, the high velocity flow past a closed branch can generate turbulence and vortices which excite an acoustical resonance frequency in the side branch. In centrifugal equipment piping systems, the noise may be caused by an acoustical resonance in the compressor case or internals or be amplified by an acoustical resonance of the piping system.

It is especially important to determine whether the noise is predominantly a pure tone or broad band frequency. Pure tones are usually associated with acoustical or mechanical resonances, whereas broad band noise is generally indicative of high energy flow velocity excitation.

After it is decided that the vibrations are high and additional analysis is needed to determine the characteristics, cause, and solution to the problem, it is necessary to develop a test plan for measuring the vibrations. To ensure that the test includes the conditions that were present during the high vibration event, it is necessary to study the operating conditions and the past data.

#### *Measure Vibration and Determine Allowables*

In cases where high vibration is noted, the analyst/engineer should make measurements to quantify the vibration. The following observations regarding the character of the vibrations should be made using a spectrum analysis.

- Frequency of vibration (low frequency less than 300 Hz or high frequency)
- Amplitude of vibration
- Location of highest vibration
- Mode shape or vibration pattern
- Steady state, transient or random vibrations

Once measurements have been made, it must be determined whether the vibrations are excessive and whether the unit must be shut down immediately to ensure the safety of the installation. With the high cost of downtime, it is imperative that the analyst/

engineer have some simple criteria or "rules of thumb" that can be used to judge the severity of the vibrations.

A fact that helps in the development of a screening criteria is that an endurance limit stress does exist for piping materials. If the dynamic stress can be kept below a certain stress level, the piping can withstand infinite cycles of the stress without failure. This stress level is called the endurance stress level.

The dynamic stress introduced into a piping span by vibration is a function of the diameter and the inverse of the square of the piping span length. The natural frequency is also a function of the diameter, divided by the span length squared. Based on this, screening criteria have been developed to eliminate the necessity to make a comprehensive analysis of every piping span in the piping system.

For transient events, the evaluation of the acceptability of the vibrations has to be determined by the application of cumulative fatigue theory.

There are basically four methods [2, 3] for evaluating acceptable vibration levels in piping systems, as listed below.

- Allowable Vibration Amplitude *V*s Frequency
- Vibration Displacement Amplitude—Stress Relationship
- Vibration Velocity Amplitude—Stress Relationship
- Measured Dynamic Strains

The step-by-step procedures used to investigating the safety and reliability of piping spans is documented in Figure 8.

*Allowable Vibration Amplitude Versus Frequency Criteria.* Acceptable vibration levels versus frequency for both lateral piping bending modes and compressor manifold modes can be obtained by using the chart given in Figure 12 [2]. This chart can be used as a screening criteria for low frequency vibrations of a piping system (frequency less than 300 Hz).

To use this chart, the measured vibration amplitudes at specific frequencies are compared to the design level amplitudes. If the vibrations are at the design level or lower, the system should be acceptable. If the levels are at the danger level, the chances of a fatigue failure are high and the vibrations must be reduced.

These criteria are very conservative for long flexible piping spans, such as those used in centrifugal equipment plant piping. They are not applicable to shell wall vibrations.

There are no readily acceptable charts for transient vibration amplitudes excited by surge or waterhammer; however, if the vibrations are higher than the danger level on Figure 12, the number of transient events should be limited.

*Vibration Displacement Amplitude as a Function of Stress.* The severity of piping span lateral vibration displacement amplitudes can be assessed by comparing the maximum resonant vibration-induced dynamic stresses to an allowable endurance limit stress. The vibration-induced stress in a piping span vibrating at resonance has been shown to be related to the maximum vibration amplitude (deflection) in the span [2, 3, 4, 8]. The relationship is given in the equation below:

$$S = K_d y \frac{D}{L^2} \quad (\text{SCF}) \quad (4)$$

where:

- S = Dynamic stress, psi
- $K_d$  = Deflection stress factor
- y = Maximum vibration amplitude (deflection) measured between nodes (normally at supports), mils
- D = Outside pipe diameter, inches
- L = Span length, ft
- SCF = Stress concentration factor



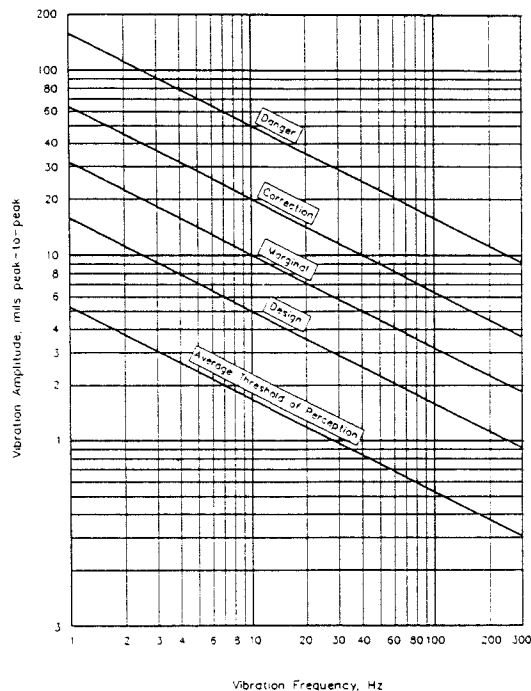

Figure 12. Allowable Piping Vibration Levels Vs Frequency.

The deflection stress factor is a function of the boundary conditions and the vibration mode shape at resonance. The deflection stress factors for the first two modes of the ideal classical beams and the piping configurations with elbows (equal leg lengths) are also given in Figure 1. These factors are used to calculate the stress at the piping span natural frequency.

For the piping configurations with elbows, the stress deflection factors were calculated with the finite element program ANSYS and presented in an earlier tutorial [2]. Plots of the deflection stress factors for the L-bend piping configuration for the out-of-plane and the in-plane modes are given in Figures 13. The deflection stress factors for the U-bend, Z-bend, and three dimensional bend are given by Wachel, et al. [2].

$$y_a = \frac{S_a}{(\text{SCF})(\text{SF})} \left( \frac{L^2}{K_d D} \right) \quad (5)$$

where:

- $S_a$  = Allowable stress, psi
- SCF = Stress concentration factor
- SF = Safety factor
- $K_d$  = Deflection stress factor

If the API 618 [6] allowable of 26000 psi peak-to-peak (single amplitude of 13,000 psi) is used as the endurance limit combined with a stress concentration factor of 4.33, a safety factor of 2.0, and a stress deflection factor of 3000 (applicable for a fixed-fixed pipe), the allowable vibration in peak-to-peak mils can be calculated.

Equation 5 becomes:

$$y_a = \frac{L^2}{D} \quad (\text{Rule of Thumb}) \quad (6)$$

This can be used (conservatively) as a screening criteria for straight runs of piping or for piping with bends. The span length

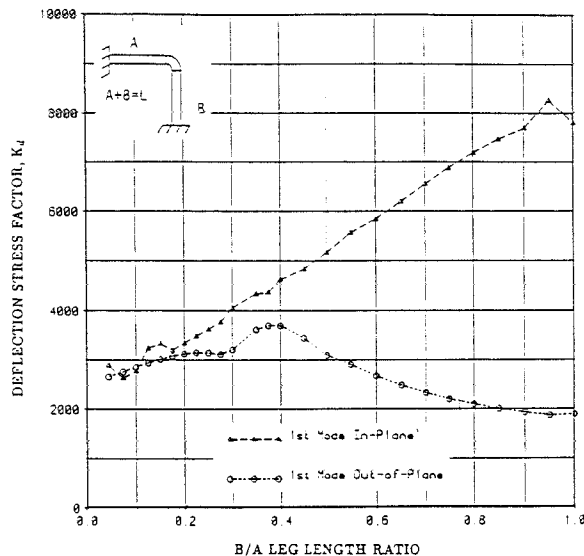

Figure 13. Deflection Stress Factors for Uniform Steel L-Bend Configuration.

is the length between measured vibration nodes that are normally at the supports. This criteria is overly conservative for cantilever beams. The vibration measurements must be made at the point of maximum vibration for the first mechanical natural frequency of the span in a lateral mode. The maximum stress occurs at the node (fixed end of the pipe) and a stress concentration factor of 4.33 and a safety factor of 2.0 are assumed. If the vibrations exceed the screening criteria, the vibration induced stresses are not necessarily excessive, and more detailed calculations using the methods described by Wachel, et al. [2], are required.

This criteria is not applicable to vibration problems other than lateral bending piping modes. It should not be applied to the compressor manifold system. For high frequency vibrations (greater than 300 Hz), the criteria described above is still applicable if the mode is a lateral bending mode. For shell wall resonances, it is very difficult to define an acceptable vibration amplitude, and equally difficult to accurately measure the vibrations. The sound pressure criteria discussed by Wachel, et al. [2], can be used as a screening criteria in many cases.

*Vibration Velocity Amplitude as a Function of Stress.* A screening criteria of 2.0 ips was developed by Wachel, et al. [2], for a piping span with a maximum concentrated weight to span weight of 2.0. For a piping span that does not have a weight in the span, the allowable is 4.0 ips. The stress concentration factor was assumed to be 4.33, the safety factor was 2.0, and the concentrated weight correction factor was 2.5. The vibration velocity must be measured at the point of the maximum vibration between the vibration nodes. As in the case of stress vs the vibration amplitude, extreme care should be taken to ensure that the frequency matches the natural frequency of the span between the vibration nodes. This is accomplished by using the methods presented by Wachel, et al. [2], to calculate the lowest mechanical frequency. Some velocity stress factors are given in Figure 1 for the classical types of straight spans and piping bends with equal legs.

The velocity measurements must be made at the point of the maximum vibration between two vibration nodes. If the vibrations are at a higher mode between two supports, the allowable can be applied if the span between the nodes is vibrating at its mechanical natural frequency. Again, it should be noted that these criteria are for identifying those piping spans that are

obviously safe. The screening criteria is very conservative for most piping systems, especially cantilevers. Most of the time, application of the criteria will eliminate the necessity of making detailed measurements of piping systems that have safe vibrations.

If the vibration velocity exceeds the screening criteria, the stresses are not necessarily excessive, however, additional calculations as outlined by Wachel, et al. [2], should be applied to evaluate in more detail the actual dynamic stress and safety factor of the piping system.

It is recommended that deflection vs stress procedures be used as discussed by Wachel, et al. [2]. This is primarily due to the corrections that have to be made in the calculations for considering other factors, such as concentrated or distributed weights, and responses at frequencies other than the first natural frequency.

**Dynamic Strain Criteria.** The allowable vibration amplitude is based on the dynamic vibration induced stress and for high cycle fatigue, the dynamic stress must be below the endurance limit for the piping material. For typical piping with an ultimate tensile strength of less than 80,000 psi, the endurance limit (stress amplitude at  $10^6$  cycles) from ASME B31.7 (Figure I-9.1) is 13,000 psi, zero to peak [9]. Since the stress is equal to the dynamic strain times the modulus of elasticity, the allowable strain would be  $866 \times 10^{-6}$  in/in, peak-to-peak. If a stress concentration factor of 4.33 and safety factor of 2 is used, it can be shown that a safe allowable strain reading for a gauge mounted near the area of high stress concentration would be  $100 \times 10^{-6}$  in/in or 100 microstrain, peak-to-peak. The applicability of this strain criteria has been field verified [10].

In cases where piping failures have occurred, it may be necessary to measure strain levels in the piping to determine the safety and reliability of the rebuilt system. The strain criteria is based on placing the strain gauge near, but not in, the area where the high stress risers are located. The guidelines for the interpretation of the strains is listed below.

#### Rules of Thumb for Strain Measurements

- Strain:  $\epsilon < 100 \mu\epsilon$  p-p Acceptable  
 Strain:  $100 \mu\epsilon < \epsilon < 200 \mu\epsilon$  p-p Marginal  
 Strain:  $\epsilon > 200 \mu\epsilon$  p-p Failure Possible

#### Determine the Source/Cause

An important part of the troubleshooting procedure is to determine if the excessive piping vibrations are a result of a mechanical or acoustic resonance (or both). A variety of measurement procedures can aid in defining the cause of the problem. Simple shock excitation methods can be used to determine the mechanical natural frequencies. Modal analysis procedures can also be used to evaluate the vibratory mode shapes of complex systems. By varying the speed of the machines and measuring the vibrations, pulsations, strain, etc., it is possible to determine the location of the mechanical and pulsation resonances. Examples of these types of data are given in Figures 14 and 15. The procedures as outlined in Figure 8 can help lead you to understand the source of the excitation causing the vibrations. The procedures outlined in Figures 9 and 10 should help in identifying the specific source of the acoustical or the mechanical resonances determined from the procedures in Figure 8.

#### Controlling Vibration in Piping Spans

Once the cause of the problem is defined, the solution is a matter of developing a practical modification which will eliminate the cause or reduce its effects. Specific treatments of vibration and pulsation problems will be discussed. The meth-

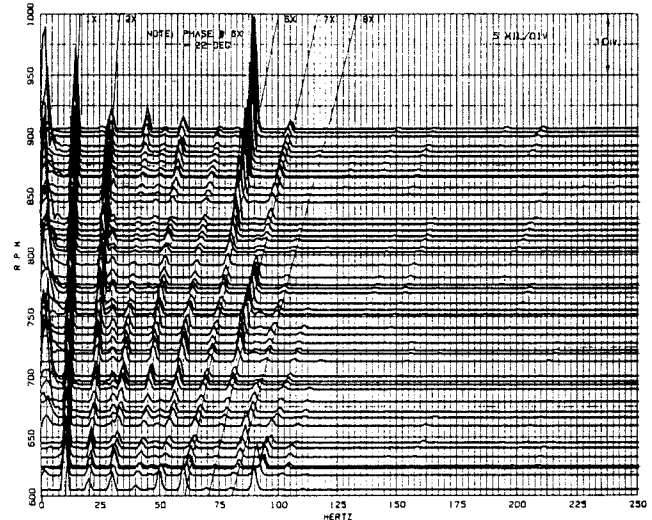

Figure 14. Vibrations of Suction Bottle Showing Mechanical Resonance.

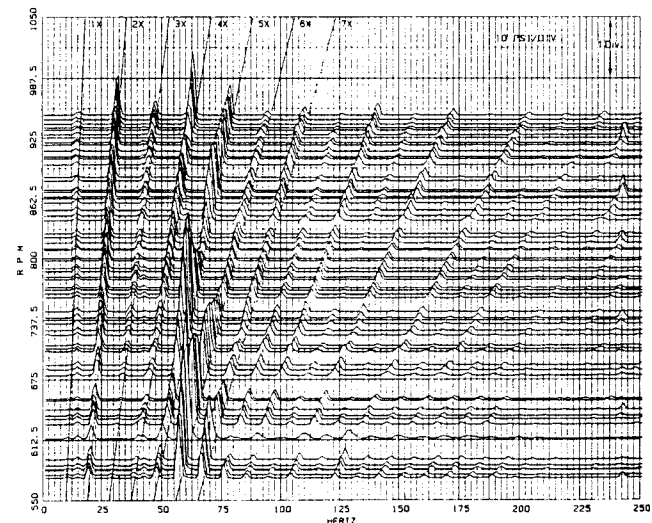

Figure 15. Discharge Nozzle Pulsation Showing Acoustical Resonances.

ods that can be used to solve the problems are summarized below:

- Detuning mechanical resonances to reduce the amplification of the energy.
- Strengthening the restraint system to absorb or withstand the dynamic forces while allowing acceptable vibration amplitudes.
- Reducing or eliminating the energy causing the dynamic shaking forces.

It is important to try possible field modifications to detune a resonance. These include the addition of stiffness, weight, damping, or possibly incorporation of a dynamic absorber.

Since a mechanical resonance amplification factor for piping is approximately 10 to 20 for most carbon steel piping, small changes in the mechanical support system can result in a significant reduction in vibration amplitude. The mechanical amplification factor for stainless steel piping can be significantly higher and values as high as 50 have been measured [2].

Stiffness added at the location of maximum vibration will be the most effective. Temporary stiffening using hydraulic jacks, comealongs, etc., may be used to determine the sensitivity of the resonance. Pipe clamps can add damping along with stiffness, particularly if a viscoelastic material is used between the pipe and the clamp. In addition to reducing the vibration amplitude, the viscoelastic material will minimize pipe wear, and provide extra resiliency for thermal movement. It should be noted that the bracing and structural supports added to improve the system can also add weight, which tends to lower the natural frequency and can offset the stiffening added.

Many times, in reciprocating machinery piping, the addition of supports will reduce the vibrations in the piping spans near the location of the added supports; however, high vibrations will be noticed at other locations. The movement of the high vibrations is most often caused by the excitation energy causing a shaking force at each elbow, change in pipe diameter, at closed ends of vessels, etc. The installation of the support changes the mechanical natural frequency near the support and can change the response frequencies of the other parts of the piping. This does not mean that the method is "moving or chasing the vibrations to other parts of the piping," it just means that the piping is poorly supported for the level of excitation energy. Sometimes it is impossible to add enough supports to control the pulsation-induced shaking forces and, in those cases, pulsation control must be used to make the vibrations acceptable.

Weights can be added to the piping spans to detune piping mechanical resonances; however, extreme caution should be exercised when this method is used. First, the changes in the natural frequency are a square root function of the added weight. This means that considerable weight has to be used in many cases. Second, the added weight lowers the natural frequency, which moves it nearer to lower harmonics that most often have the highest energy level in reciprocating compressors and pumps. Third, changes in the speed of sound which lowers the excitation frequencies, or reductions in the running speed can excite the new mechanical natural frequency of the span with even higher vibrations.

A dynamic absorber can be used as a temporary solution if it is properly designed and installed. A dynamic absorber for piping would be clamped to the piping and would typically have a flat bar for the spring and a movable mass that can slide in and out from the pipe to tune its mechanical natural frequency to the span mechanical natural frequency. In using a dynamic absorber, the dynamic absorber vibrates at the piping span natural frequency and the amplitudes of the pipe span would be reduced. The dynamic absorber actually creates two additional mechanical resonances, one below and one above the original natural frequency. The location of these natural frequencies is determined by the weight ratio of the absorber weight to the effective modal weight of the piping span that was vibrating at resonance. If the new resonances were near other excitation harmonics, high vibrations at other harmonics can occur. It is usually preferable to change the support spacing or add support stiffness to the system to solve the problem.

The vibration amplitudes are a function of the total stiffness of the piping supports. For example, if the piping system is nonresonant, the vibration amplitude is proportional to the shaking force divided by stiffness of the system. Whenever a resonance is incurred, the amplitudes are the amplification factor times the nonresonant amplitude. If stiffness is added to a piping system, piping vibrations should be reduced unless the mechanical resonance is moved to a frequency where there is greater energy.

If a mechanical resonance is the cause and practical temporary modifications can not be evaluated, the analyst may need to

develop simple or more complex finite element models of the system to evaluate potential solutions.

If the high vibrations are caused by high pulsations, acoustical control techniques should be used to reduce the vibrations. These acoustical control techniques will be discussed in a later section. One of the test procedures that is used to determine if vibrations are caused by pulsation-induced shaking forces is to remove the compressor suction valves. If the suction valves are removed the pulsations are eliminated; therefore, the only remaining forces are those caused by the mechanical forces and moments. Results from a field test in which the suction valves were removed are shown in Figure 16.

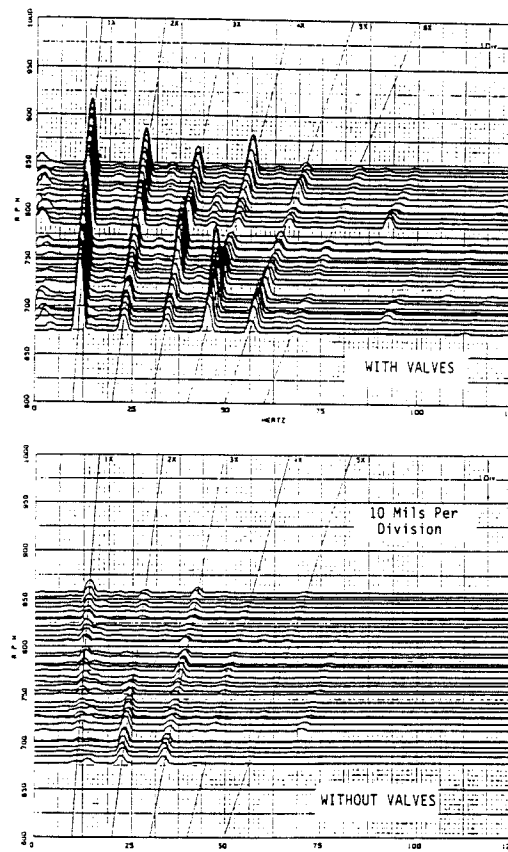

Figure 16. Comparison of Suction Bottle Vibration with and without Suction Valves Removed.

## COMPRESSOR MANIFOLD RESPONSES

Vibration problems in reciprocating compressor installations are often associated with the compressor manifold system [3, 11]. A typical two-cylinder compressor manifold system is shown in Figure 17. Two compressor cylinders are connected to the compressor frame by the crosshead guide and distance piece. Common suction and discharge bottles are shown in this case. Secondary pulsation bottles are often used and can be oriented horizontally near the grade elevation, vertically to minimize unsupported riser dimensions, or may even be fabricated as part of the primary filter bottle.

### Evaluation of Vibrations in Compressor Manifold Systems

Compressor manifold system vibrations can be evaluated by using the screening criteria given in Figure 12. It is desirable for the vibration levels to be at or below the design line. If vibrations

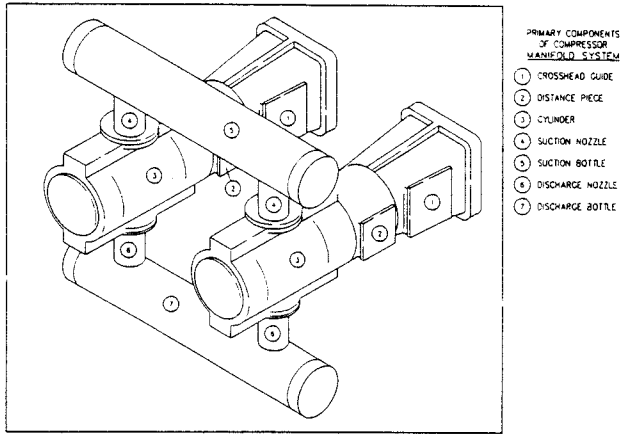

Figure 17. Primary Components of Compressor Manifold System.

are above the danger line, immediate steps should be taken to reduce amplitudes. The mode shape should be evaluated to determine the most likely location of the highest stress. The best way to determine the safety of the installation is to install strain gages at the potential high stress locations and record the strains over the speed range of the unit. The strain amplitude criteria discussed above is applicable for this evaluation. The complex wave peak-to-peak strain level should be less than 100  $\mu$  in/in to ensure that the system is safe. Strain data obtained on a compressor manifold system at the suction nozzle where a fatigue failure had occurred are given in Figure 18. The peak-to-peak strain was greater than the allowable 100  $\mu$  in/in at several speeds and at the mechanical resonance, it was greater than the failure level of 200  $\mu$  in/in.

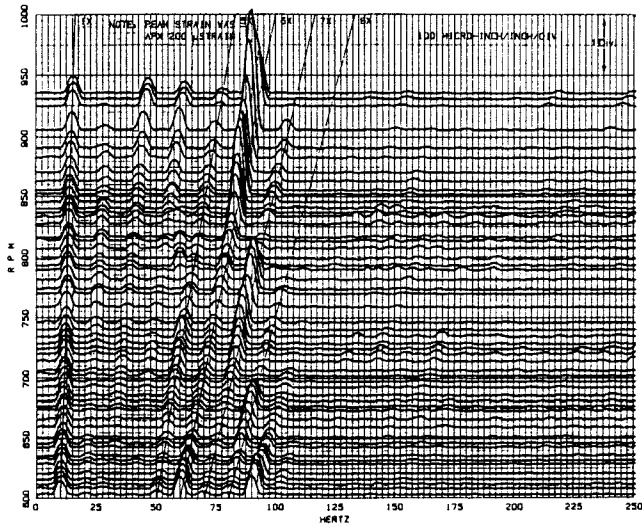

Figure 18. Dynamic Strain Measured on Suction Nozzle Showing Effects of Mechanical Resonance of Figure 14.

Vibration Modes

A general purpose finite element computer program with dynamic analysis capabilities was used to evaluate the system dynamics of the two cylinder example (Figure 17). The classical vibration mode shapes are illustrated in Figures 19, 20, 21, 22, 23, and 24. It is useful to understand these modes and the effective means of controlling them when analyzing vibrations in reciprocating compressor installations.

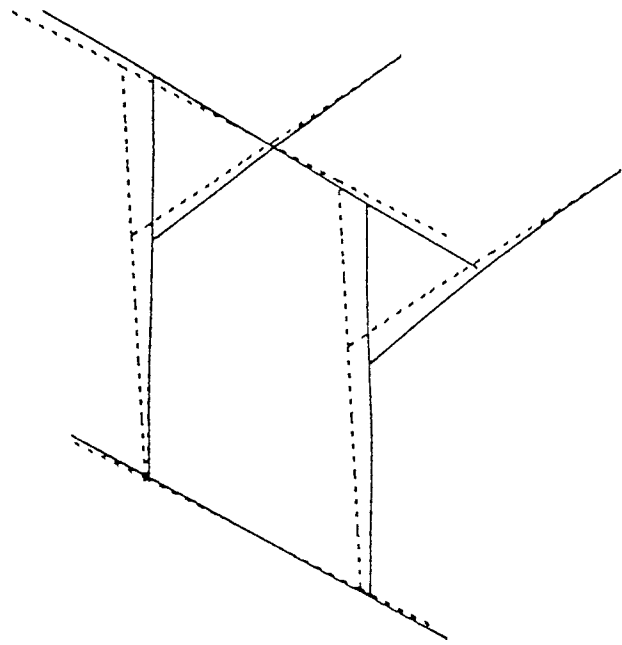

Figure 19. Low Mode of Compressor Manifold System.

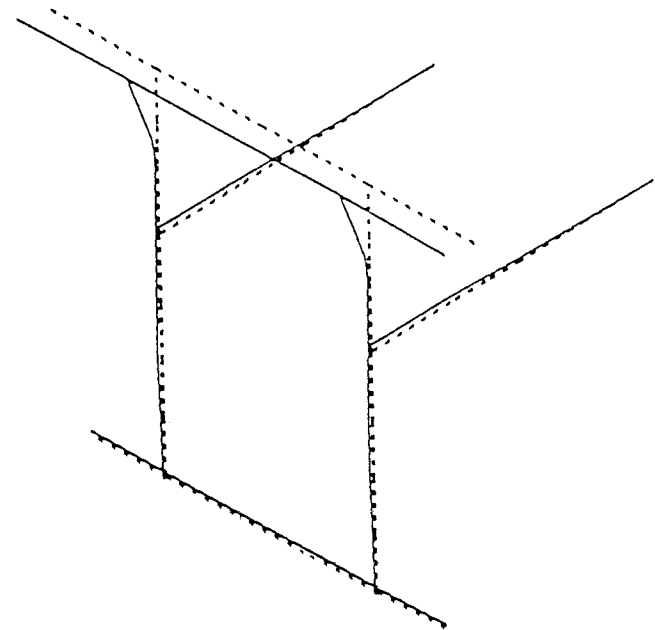

Figure 20. Suction Bottle Cantilever Mode of Compressor Manifold System.

Low Mode

The "low mode" is illustrated in Figure 19 and is generally the lowest frequency mode of the structural system. The mode shape is basically a rigid body motion with the cylinders and bottles all vibrating in-phase. If the frequency of this mode is coincident with a pulsation induced shaking force frequency or a mechanical excitation at a significant harmonic of compressor speed (generally 1 $\times$  or 2 $\times$ ), high vibration levels and fatigue failures can result. The failure mode is often a torsional failure of the nozzles.

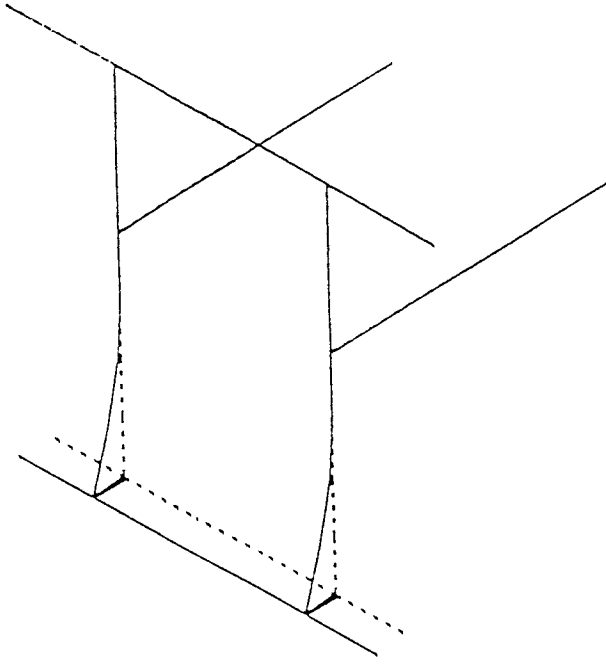

Figure 21. Discharge Bottle Cantilever Mode of Compressor Manifold System.

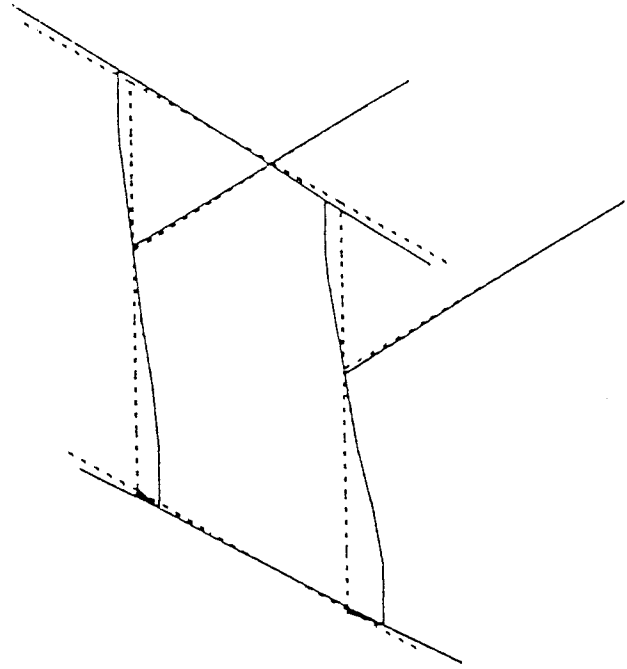

Figure 23. Rotary Mode of Compressor Manifold System.

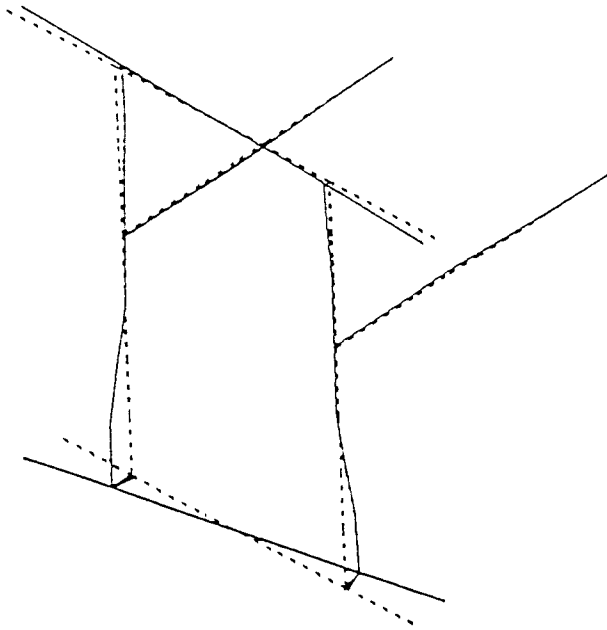

Figure 22. Angular Mode of Compressor Manifold System.

#### Bottle Cantilever Resonances

There are two bottle "cantilever modes" for this type of system. One mode will occur with both ends of the bottle in phase; the other mode will have the ends of the bottles vibrating out-of-phase with a node near the center of the bottle (Figures 20, 21, and 22). Depending on nozzle lengths and diameters, bottle sizes, and branch connection flexibility, these modes can be lower in frequency than the low mode. If such a mode is excited by either acoustical or mechanical forces, high vibration and fatigue failures can result. The typical failure mode would

be a bending failure of the nozzle near the cylinder flange on either the front or back side.

#### Rotary Mode

The "rotary mode" illustrated in Figure 23 involves the suction and discharge bottles moving out-of-phase, but in the plane of the manifold bottles. If this mode were excited, the highest stress points would be on the sides of the nozzles at the bottle-nozzle junction or at the cylinder flanges.

#### Cylinder Resonance Mode

The "cylinder resonance mode" shown in Figure 24 involves out-of-phase motion of the cylinders. With more than two cylinders, various combinations of one cylinder moving out-of-phase with the others will occur. Therefore, there will be several cylinder resonance modes. The highest stress levels occur on the sides of the nozzles at the nozzle bottle junction.

There are other possible vibratory modes that can occur for a given system, such as suction riser modes, single cylinder/bottle modes, secondary bottle modes, etc. All of these modes can cause failures, if not properly controlled.

#### Controlling Vibrations in Compressor Manifold Systems

To minimize vibration problems with the compressor manifold mechanical system, it is desirable to have the mechanical natural frequencies above  $3\times$  compressor speed, if possible, and not be coincident with any of the shaking force peak frequencies. The following paragraphs discuss methods of controlling compressor manifold system natural frequencies and vibrations.

It is generally desirable to keep the nozzles short to raise the mechanical natural frequencies. Long suction nozzles are often desirable to provide access for maintenance of valves or to permit instrumentation fittings to be installed; however, they cause the mechanical resonances to be lower, thus increasing the possibility of a resonance occurring with the higher energy excitations. Heavier wall nozzles are also desirable to provide additional stiffness to the structural system, even though they may not be required for the pressure rating.

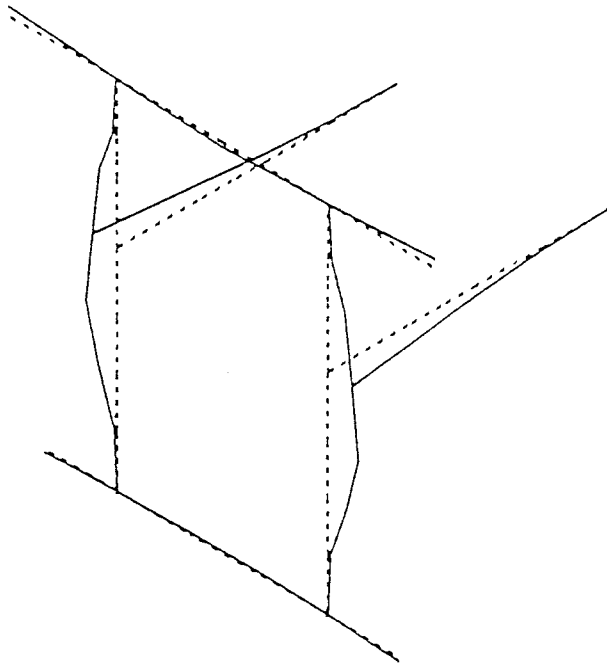

Figure 24. Cylinder Resonance Mode of Compressor Manifold System.

One of the most effective means of controlling system mechanical natural frequencies is the use of proper discharge bottle supports. A high percentage of all compressor installations designed according to API 618 specifications utilize some sort of discharge bottle support. The most effective support design uses both a strap and wedge, which can significantly affect the low mode, the discharge bottle cantilever mode, the rotary mode, and the angular mode, by increasing the mechanical natural frequency and lower the amplitudes. Weight supports and wedges without straps are generally not as effective. The clamps are most effective when a viscoelastic material is used between the clamp and bottle to improve surface contact. The wedges are intended to be tightened at operating temperature to avoid thermal stress concerns.

Dynamic cylinder supports are perhaps the most effective means of raising the low mode above the range of expected excitation frequencies. A plate-type support attached to the cylinder head bolts is often used and is illustrated in Figure 25. Some compressor manufacturers provide attachment holes for this type of support, so that the pressure containing bolted joint is not used. The cylinder support should be shimmed and tightened at operating temperature and is not intended as a cylinder alignment device. It is also important to note that the support is designed to be flexible in the cylinder stretch direction (perpendicular to the crankshaft).

Some of the natural frequencies of the compressor manifold system can be detuned using simple braces. For example, since the cylinders vibrate out-of-phase in the "cylinder resonance mode," this mode can be stiffened by simply tying the cylinders together. An example of this is demonstrated in the data in Figure 26.

Suction risers can be a problem, especially if too many elbows are used. Elbows add flexibility (reduce stiffness, and therefore, mechanical natural frequency), and create a force coupling point. Secondary suction bottles are sometimes mounted vertically to minimize the length of an unsupported riser. When this approach is taken, special attention to the mounting details of the vertical vessel is required. Sometimes special concrete piers or

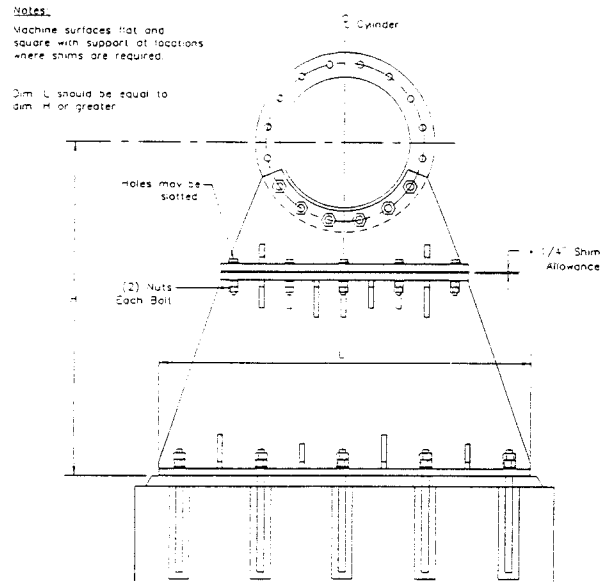

Figure 25. Dynamic Cylinder Support.

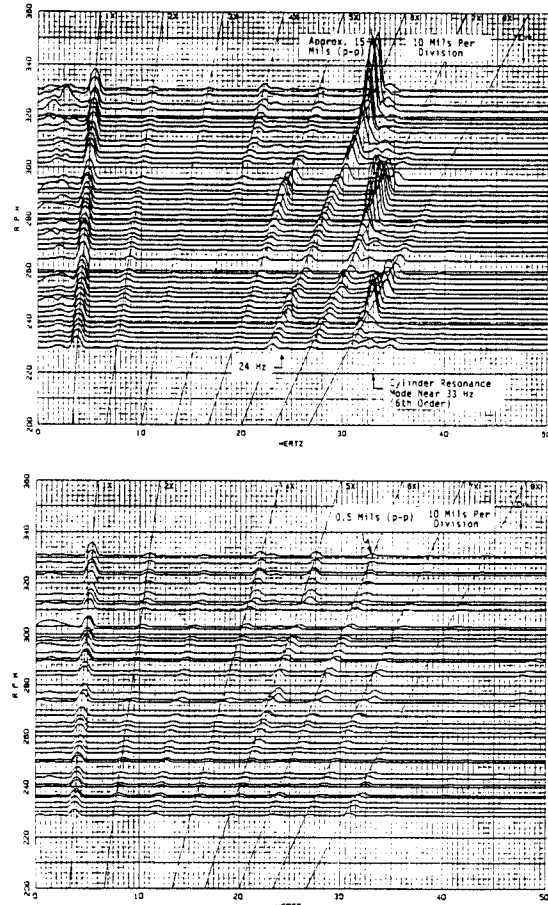

Figure 26. Elimination of Cylinder Resonance Mode By Bracing Between Cylinders.

truss-type structures are necessary to support suction risers if they become too long and flexible.

**COMPRESSOR/ENGINE  
FRAME DYNAMIC VIBRATION**

Another problem that occurs in reciprocating machinery systems is vibrations of the compressor/engine frame due to the large forces and moments at one and two times running speed. When failures of the crankshaft, the anchor bolt system, or the grout-foundation system occur, the problem can be related to an inadequate engine-foundation tie-down system [3,12,13]. The tie-down and anchoring system has to absorb and transfer the mechanical and pulsation forces generated in the compressor/pump system to the foundation.

A major problem in such systems is that the metal frame has a different thermal expansion coefficient than the epoxy grout. The thermal expansion coefficient for steel/cast iron frames is approximately  $6.7 \times 10^{-6}$  while a typical value for epoxy grout is approximately  $20 \times 10^{-6}$ . This means that differential movement is possible, which can eventually cause cracking of the grout and decrease the effectiveness of the interface. This is why some older units begin to have crankshaft and bearing problems after many years of successful operation without failures.

The resisting force between the frame and the foundation depends upon the frictional component of the frame to grout/sole plate interface. The friction force is a function of the bolt preload and the coefficient of friction between the two surfaces. Several factors determine the coefficient of friction. For dry surfaces, the coefficient can be as high as 0.3; however, if the surface has lubrication (such as a leak from the crank case doors) the coefficient can drop to 0.15. With vibrations (which obviously occur), the coefficient can fall to less than 0.1. This means that it is extremely important to maintain good housekeeping to keep the oil leaks from getting between the frame and the grout/sole plates.

*Frame Dynamic Misalignment*

The forces and moments transmitted to the foundation through the anchor bolts are a function of the frame flexibility and are much higher than the values calculated, based on the assumption that the frame is rigid. This can result in slippage of the frame on the grout or rail interface. Some units may have chronic maintenance problems, such as loosening bolts on inspection covers, oil leaks, etc. Excessive differential frame bending can cause anchor bolts to loosen, foundation cracking, and even main bearing or crankshaft failures.

Relatively low amplitudes of differential frame bending (vibration) can be detrimental to reciprocating machinery reliability. A complete discussion of the various measurement techniques used to evaluate the adequacy of the foundation-support system is given in Atkins, et al. [13]. Suggested field vibrations measurement locations are shown in Figure 27. Measurements should be obtained at each elevation, moving the reference accelerometer to the corresponding elevation each time. It is useful to make a summary plot of differential vibration data obtained from all elevations measured. A summary plot is shown in Figure 28. These measurements can reveal loose anchor bolts, failed grout, cracked foundations, excessive bending of the crankshaft, and other problems. The diagnosis of loose bolts and the measurements after the bolts were retorqued is shown in Figure 29.

It is also possible to use modal analysis techniques to measure the operating deflection shape of the compressor-foundation system (Figure 30). Atkins and Price [13] discuss these types of measurements and how they can be used to analyze a variety of problems.

To control these types of vibrations, the anchor bolts should be tightened to the maximum allowable preload, the interface between the frame and the sole plate or grout should be kept dry

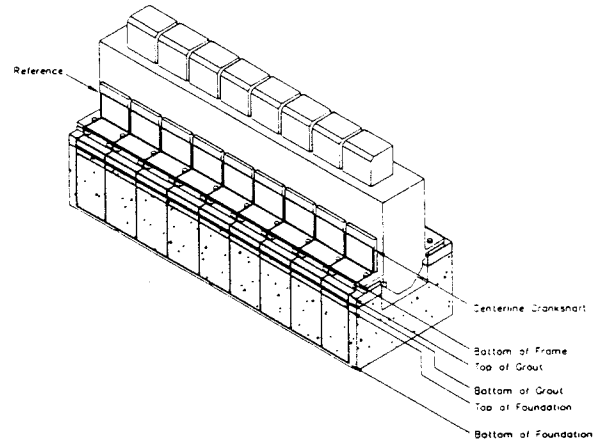

Figure 27. Typical Measurement Locations For Determining Dynamic Differential Vibrations.

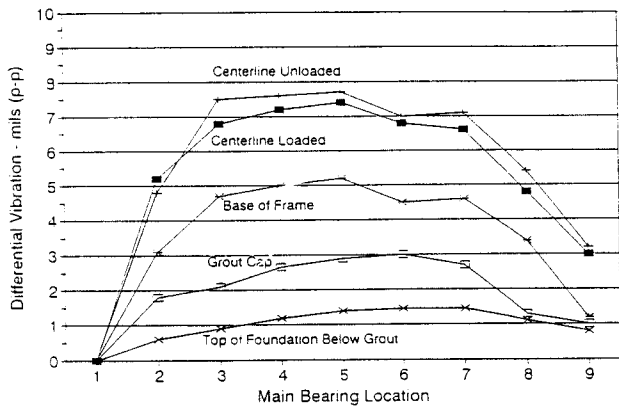

Figure 28. Compressor Differential Vibration at Different Elevations.

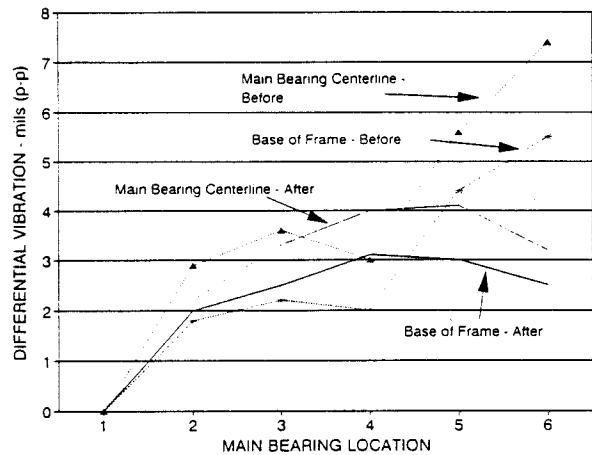

Figure 29. Compressor Differential Vibration Before and After Re-Torquing Bolts.

and free from the oil, and the foundation/grout interface should be free from cracks, etc. It may be necessary to regROUT the foundation, or to add additional horizontal resistance by the use of grouted-in outriggers which resist horizontal movement.

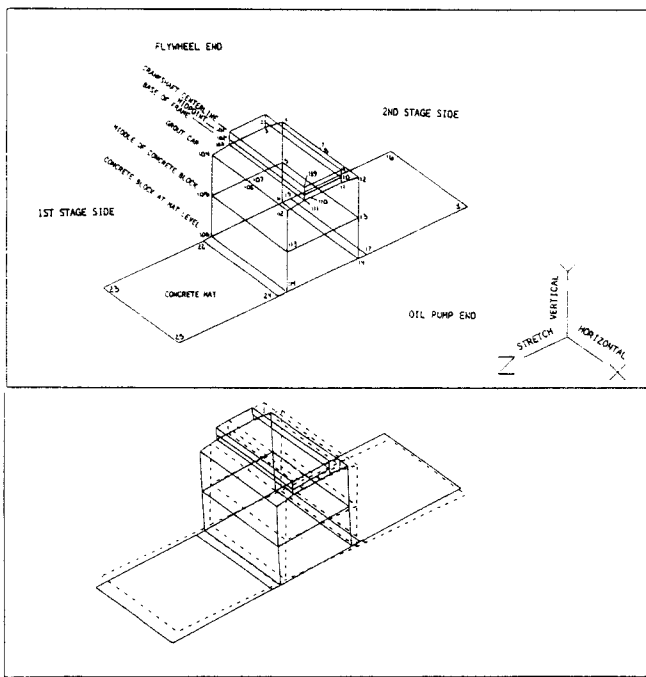

Figure 30. Foundation Rocking Mode Measured Using Modal Analysis Techniques.

#### Foundation/Soil Vibrations

Reciprocating machines can generate excitation forces near one of the foundation-soil mechanical natural frequencies. Foundations have six rigid body natural frequencies ( $X, Y, Z, \theta_x, \theta_y, \theta_z$ ), which are a function of the weight and moments of inertia of the foundation and machinery and soil stiffnesses. The unbalanced forces and moments from the machinery act above the center of rotation (which is normally below the foundation mat) and for systems with weak soil, the vibrations can become excessive. It is difficult to define the acceptable levels of vibration; however, the manufactures of the drivers and the compressor generally have specifications for the frame.

When high vibrations are measured on a system, it is necessary to make detailed measurements to ascertain whether the foundation system natural frequency is being excited or if the forces and moments are excessive. In order to define the foundation natural frequencies, it is desirable to measure the vibrations over a speed range. If the unit is motor-driven, a mechanical shaker may be required. The results of a test which showed that the compressor/foundation system had a natural frequency at the compressor second harmonic are shown in Figure 30. Most often the natural frequency that is excited is a rocking mode about a point below the mat. Modal analysis techniques that can define the mode shapes of the foundation and the compressor piping are often used since the separation of the effects of the rigid body foundation rotation from the compressor vibrations caused by mechanical or acoustical shaking forces is difficult to determine.

To control vibrations caused by foundation related problems, it may be necessary to extend the mat, retrofit piles that go down to bedrock, or reduce the forces and moment that are causing the vibrations.

#### OTHER STRUCTURAL RESPONSES

There are other types of vibration problems with the piping systems that can occur; however, they are not as predominant as the problems with the piping spans and the compressor manifold

systems. These include shell wall vibrations, valve/valve component vibrations, and structural resonances.

#### Piping Shell Wall Responses

Piping shell wall resonances can occur in large diameter vessels and in blow down or flare lines. Shell wall resonances are a function the pipe wall thickness and inversely as the square of the diameter. Changing the wall thickness will change the natural frequencies and will reduce the vibrations for a given energy input level by "mass loading," plus the increase in stiffness. Often, straps with viscoelastic material between the clamps and the vessel can adequately attenuate the high frequency shell wall vibrations.

#### Valve and Valve Component Responses

Valve problems are experienced on valves mounted on appurtenances which are excited by pulsation energy coincident with the mechanical natural frequency of the stub. Other valve problems will occur with the blow down pressure relief valves when the flow becomes near sonic. To define the severity of the vibrations, measurements should be made during the event. Many problems occur with the instrumentation tubing due to the high energy dissipated by the letdown in pressure.

#### Structural Responses

There are other problems encountered in plants with reciprocating machinery that are caused by structural resonances. Noteworthy of these are large scrubbers, cooling towers, structures that have equipment attached, and piping racks. The high vibrations can sometimes be significantly reduced if the natural frequencies can be detuned. Similar testing methods to those used to investigate the pipe vibration can be used.

#### PULSATION IN RECIPROCATING MACHINERY PIPING

Pulsations are the major cause of high piping vibrations and reduced reliability in reciprocating compressor and pump piping systems [2, 3, 11]. Therefore, it is important to understand how pulsations are generated and how they can be controlled, so that proper design decisions can be made.

Pressure pulsations are a result of oscillatory flow (pulsative flow) induced by the fluid (gas or liquid) transmission equipment. In addition to causing vibration, excessive pulsation in compressors can also significantly distort the pressure-volume card, reduce compressor capacity and efficiency, and reduce valve life. Excessive pressure variations in pumps can result in overload of pump working components and cavitation. Excessive pulsations can also cause significant errors in flow measurement.

In order to reduce the potential for piping and vibration problems in the design stage or to solve problems with existing reciprocating machinery systems, several concepts should be understood:

- Acoustical excitation mechanisms
- Piping acoustical response
- Acoustical-mechanical coupling
- Techniques for control of pulsations and resulting shaking forces

#### Acoustical Excitation Mechanisms

The intermittent flow of a fluid through compressor or pump cylinder valves generates fluid pulsations that are related to a number of parameters, including operating pressures and temperatures, clearance volumes, cylinder phasing, fluid thermodynamic properties, etc. Pulsations are generated at discrete



frequency components corresponding to the multiples of operating speed.

The flow modulations shown in Figure 31 are produced by a double acting compressor cylinder. Two "slugs" of flow are produced per revolution, and the even harmonics are typically higher in amplitude than the odd harmonics. Similar data are shown in Figure 32 for the combined cylinder flow of a triplex pump. The harmonics of flow corresponding to the integer multiples of the number of plungers (i.e., three, six, nine for a triplex pump) are dominant, and for symmetrically acting (equal performance) plungers and valves, the harmonics of the combined plunger flow are (theoretically) exactly zero at other harmonics.

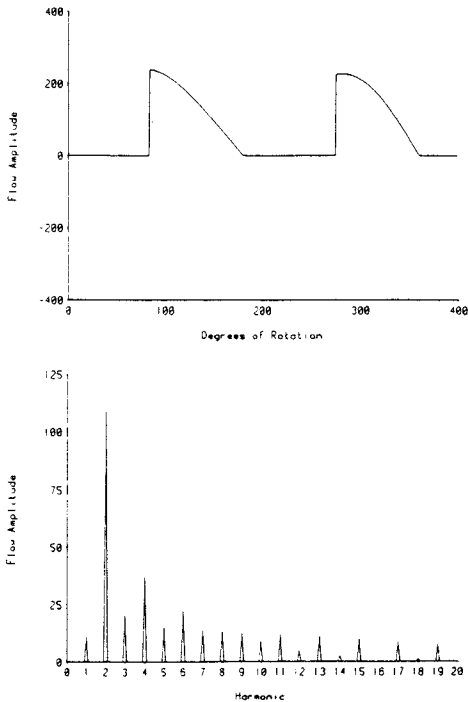

Figure 31. Flow Vs Time Wave (Top) and Flow Frequency Spectrum (Bottom) of Double Acting Compressor Cylinder (L/R = 5, Ideal Valves).

**Piping Acoustical Response**

In order to solve piping vibration problems or to design safe and reliable piping systems, the piping acoustical responses can be simulated using digital or analog procedures. Such techniques are discussed in codes such as *API 618 Reciprocating Compressors for General Refinery Services* [6] and *API 674 Positive Displacement Pumps-Reciprocating* [14]. A computer-based acoustic simulation technique, developed by EDI and verified by field measurements, is routinely used to simulate the overall acoustic characteristics of compressor and pump piping systems and, thereby, aid the analyst in developing piping systems that control pulsation.

The acoustic simulation software is outlined in Figure 33. The simulation code is based on the one dimensional, damped wave equation that is derived from the momentum, continuity, and state equations. Surrounding the simulation code are various input file structures, preprocessors and postprocessors which facilitate the use of the system. This software system is used to describe various characteristics of one-dimensional acoustics.

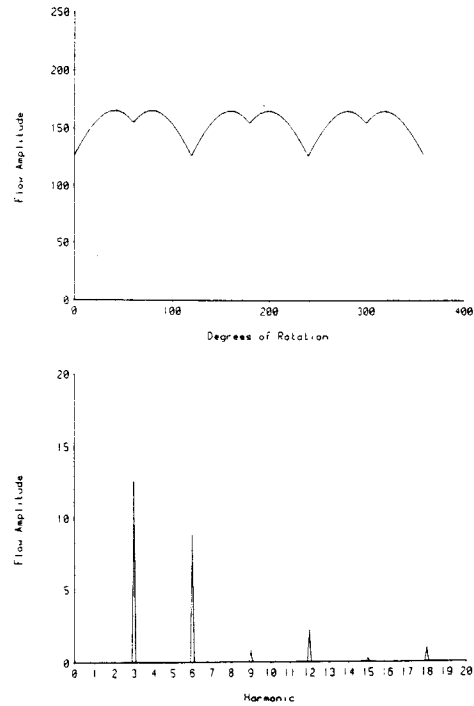

Figure 32. Flow Vs Time Wave (Top) and Flow Frequency Spectrum (Bottom) of Ideal Triplex Pump.

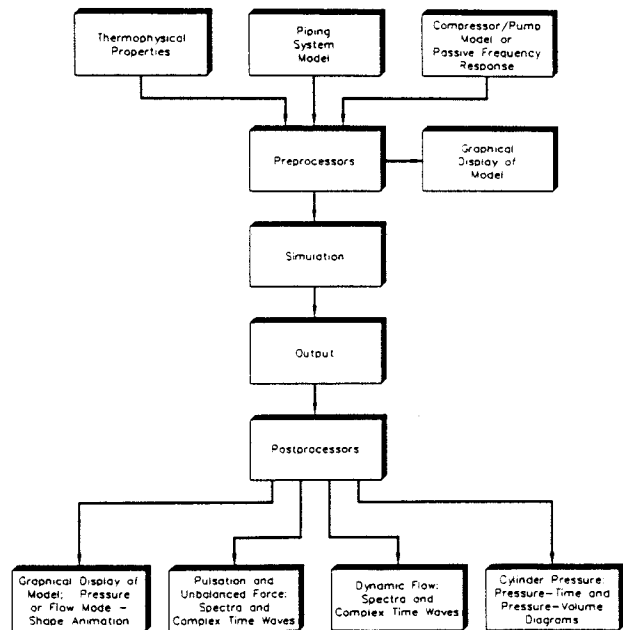

Figure 33. Block Diagram of Digital Computer Based Acoustic Simulation System.

**Acoustic Velocity and Wave Propagation**

For the normal range of pulsation frequencies of importance in reciprocating machinery piping, the pulse from the compressor or pump cylinder travels essentially with a flat plane wave front, since the pipe diameter is small compared to the wave length of the acoustical wave. Therefore, a one-dimensional model in which the pressure (and flow) properties are assumed to vary only along the length of the conduit and are constant over

the cross sectional area is the basis of the concepts presented here.

The wave travels with the speed of sound in the fluid. The speed of sound in gas or liquid mixtures is typically calculated using equations of state. Values of the speed of sound for gases typically range from 800 to 3000 ft/sec; for liquids, the speed of sound is usually 3000 to 5500 ft/sec.

The flexibility of the pipe wall produces an effect that lowers the speed of sound and should be accounted for in liquid systems, but is normally insignificant in gas systems with steel piping (since the bulk modulus of liquid is much higher than that of a gas).

The computer model shown in Figure 34 is of a simple infinite length line with a sinusoidally varying mass-flow excitation at one end. This excitation is equivalent to a piston being displaced back and forth, with a constant amplitude at angular frequency in a steady-oscillatory fashion, with the piston motion described by:

$$x = X \sin(\omega t)$$

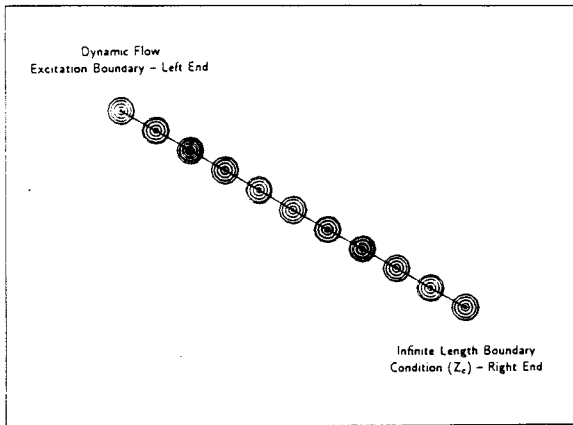
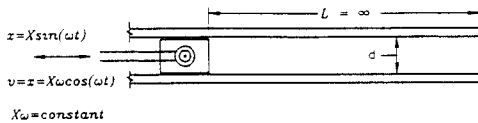

Figure 34. Animation of Traveling Wave in Infinite-Length, Constant Diameter Pipe.

Since the pipe is infinitely long, no acoustic reflection occurs and the system is nonresonant. A continuous train of compressions and rarefactions travels along the *infinitely* long tube, with each point undergoing a full cycle of dynamic pressure. In the absence of damping, the amplitude at each point would be identical. The wavelength of the pressure wave is related to the acoustic velocity,  $c$ , and the frequency,  $f$ , by the relationship:

where:

$$c = \text{speed of sound, fps}$$

$$f = \frac{\omega}{2\pi} = \text{frequency, Hz}$$

Assuming an infinitely long tube (i.e. no reflections from the end of the tube), Newton's law may be applied to show that the amplitude of the pressure wave will be:

$$P = \rho c (x\omega) \sin \omega t = \rho c u \sin \omega t$$

where:

$$\rho = \text{mass density, } \frac{\text{lb-sec}^2}{\text{in}^4}$$

$$c = \text{speed of sound, } \frac{\text{in}}{\text{sec}}$$

$$x = \text{piston displacement amplitude, in}$$

$$\omega = \text{circular frequency of piston, } \frac{\text{rad}}{\text{sec}}$$

$$u = x\omega = \text{piston velocity amplitude, } \frac{\text{in}}{\text{sec}}$$

The amplitude of the pressure wave  $\rho c u$  is proportional to the velocity of the piston  $u$ . This concept is fundamental to understanding the source of pulsations in reciprocating equipment. Also note that the pressure pulsation amplitude is proportional to the density and speed of sound.

The mode shape information of Figure 34 may be displayed in time and is useful for visualizing mode shapes. The animated mode shape display uses the following logic in demonstrating the mode shape: at the location of the maximum positive pulsation amplitude, the amplitude is represented by a large diameter circle. At the minimum negative pulsation peak, the pulsation amplitude is represented by a dot. Thus, the largest diameter circle and the dot at a given test point have the same amplitude, but are 180 degrees out-of-phase. For the zero pulsation amplitude, the circle is approximately one-half the diameter of the maximum positive peak. Note that at a pulsation node, the amplitude of the circle does not change.

#### Acoustical Wave Reflections

When an acoustic wave propagating down a pipe reaches an impedance discontinuity, a reflection takes place. The impedance value in a piping system changes at:

- Closed ends.
- Open ends.
- Piping diameter changes.
- Branches.
- Tees.
- Restrictions.
- Change in density or acoustic velocity.

Changes in impedance in the piping are necessary for acoustic waves to reinforce and result in resonance. While full reflections will occur at zero or infinite impedances in a pipe, intermediate changes in cross sectional area will have an intermediate effect. The ratios of reflected pressure  $P_r/P_i$  and the ratio of transmitted pressure  $P_t/P_i$  are a function of the area ratios of the pipes.

#### Acoustic Standing Waves

Two waves traveling in opposite directions will result in the classical standing wave if the frequency of the two waves are equal to a characteristic frequency of the pipe length and if they have a certain phase relationship. One of the waves may be thought of as the incident wave, the other as the reflected wave. The superposition of these two waves produces fixed locations of maxima and minima, i.e., a standing wave. These concepts can be applied to describe some of the classical length resonances and mode shapes in terms of standing waves. Resonances associated with distributed systems of constant pipe diameter have mode shapes described by portions of sinusoidal waves (half waves, quarter waves, etc.), as shown in Figure 35.

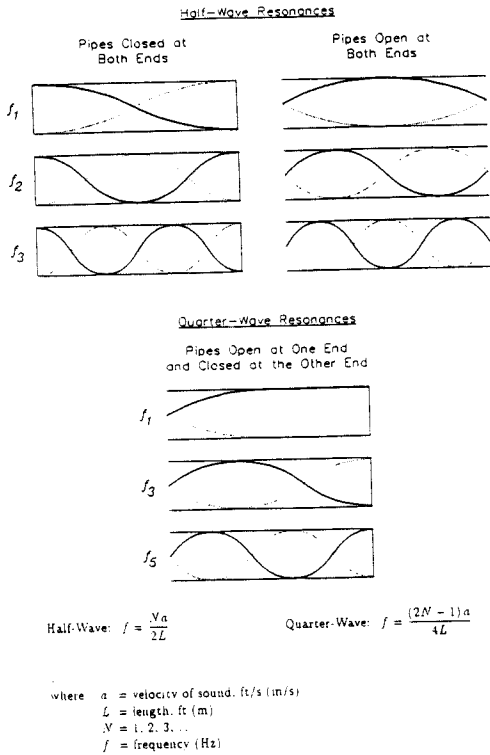

Figure 35. Organ Pipe Resonant Pressure Mode Shapes.

**Half-Wave Resonances.** Consider the closed-closed system of Figure 36. The pipe is assumed to be 30 ft long, the diameter is 4.0 in, and the speed of sound is 1200 ft/s. Using the equation for the half-wave resonance frequencies:

$$f_n = \frac{nc}{2l}, n = 1, 2, 3, \dots,$$

the resonant frequencies of the system are

$$f_n = 20, 40, 60, 80, \dots \text{ Hz}$$

Assume that the piston undergoes oscillation  $x = X \sin \omega t$  so that the peak piston velocity ( $\dot{x} = X \omega \cos \omega t$ ) amplitude  $X \omega$  is constant, and that the frequency  $f$  of the piston is varied slowly from a very low frequency to 100 Hz. The velocity amplitude  $X \omega$  for the example is arbitrary, but constant over the frequency range 0 to 100 Hz.

If the amplitude of pulsation in psi p-p at a particular point along the pipe (A, B, or C) is plotted over the frequency range of excitation (0 to 100 Hz), the frequency response amplitude of the pulsation over that frequency range is obtained. (Note that the pulsation spectra amplitudes are normalized to an arbitrary amplitude.) The mode shape of the fundamental mode at 20 Hz of this resonant frequency is also shown in Figure 36. A node is apparent at the midpoint as the circle diameter is constant. Antinodes occur at the ends as the diameter of the circle varies from zero to a maximum value.

**Quarter Wave Resonances.** Similar results for a quarter-wave stub (right end open) are shown in Figure 37. The resonant frequencies for this system are:

$$f_n = \frac{nc}{4l}, n = 1, 3, 5, \dots,$$

$$f_n = 10, 30, 50, \dots$$

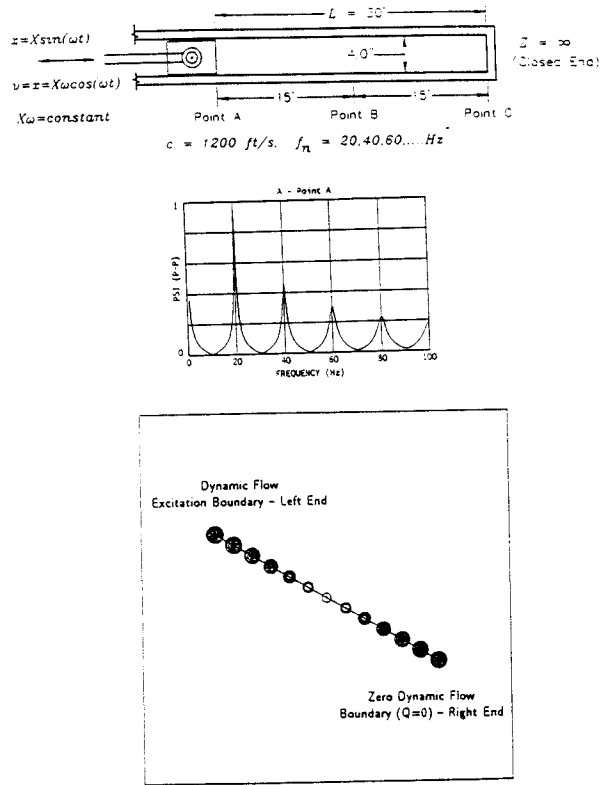

Figure 36. Frequency Response (Middle) and Animation of Fundamental Mode of Closed-Closed (Constant Diameter) Pipe.

The animated mode shape for the fundamental resonant frequency at 10 Hz are shown in Figure 37. The pressure variation is zero at the right, open end. Therefore, the diameter of the circle at this point is constant. The left end is a pressure antinode.

A quarter-wave resonance can cause erroneous measurements when used to take dynamic pressure data. A typical test connection, depicted in Figure 38, with a short nipple and valve connected to a main line make up a quarter-wave stub. This length can tune up to pulsations in the main line, and cause the needle on a pressure gage to oscillate and indicate severe pressure variations that do not actually exist in the main line. Similarly the data from a dynamic pressure transducer can be erroneous due to this stub or channel resonance.

**Volume-Choke-Volume Filter Resonances.** An acoustic filter consists of two volumes connected by a relatively small diameter pipe (choke tube). The volumes of the two chambers serve as acoustic compliances, while the fluid in the choke tube serves as an acoustic inertance. The combination of these acoustic elements in this manner produces a "low pass" filter that attenuates pulsation at frequencies above its "cutoff" frequency. An acoustic model of a volume-choke-volume filter and the passive frequency response of the system at the one-quarter point of the choke tube is shown in Figure 39. The resonant peak at frequency  $f_H = 10.5 \text{ Hz}$ , is referred to as the Helmholtz frequency of the two-chambered filter, and will amplify pulsations at that frequency. In addition to the Helmholtz resonance of a two-chambered filter, internal resonances of the filter elements can have the effect of "passing" particular frequencies. The choke tube acts as an open-open pipe, such that a pass band occurs at the half wave length resonance of the choke at 112.5 Hz. The animated mode shapes for the low mode filter frequency and of the choke tube pass-band frequency are shown in Figure 40.

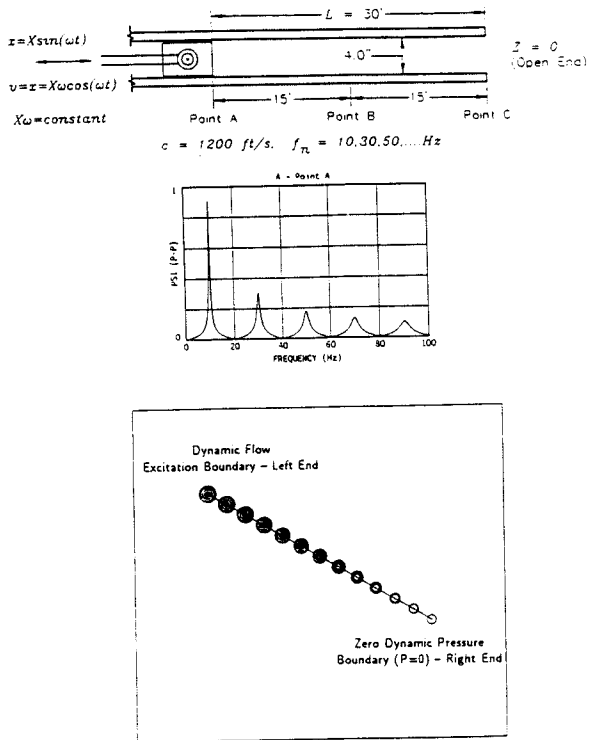

Figure 37. Frequency Response (Middle) and Animation of Fundamental Mode of Closed-Open (Constant Diameter) Pipe.

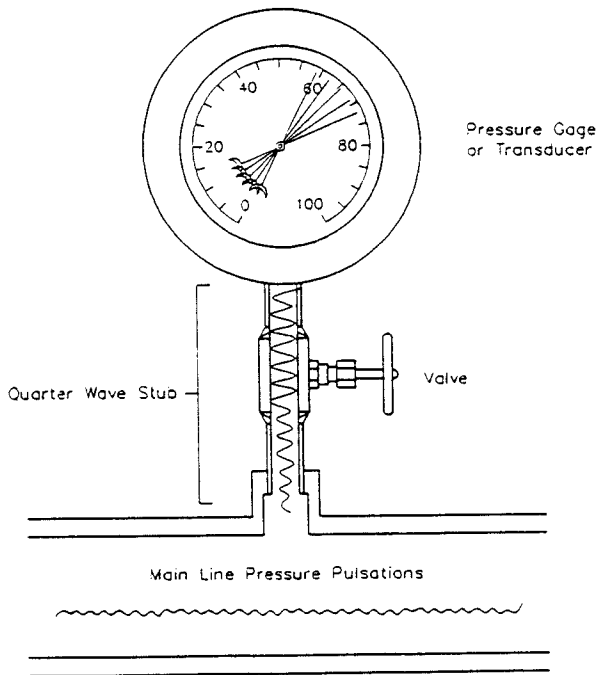

Figure 38. Erroneous Pressure Measurements Caused by Stub Resonance.

Resonances in Actual Piping Systems

Actual piping systems do not usually have the idealized acoustic resonant mode shapes previously described. The only perfect (complete) reflections that are realized in piping systems

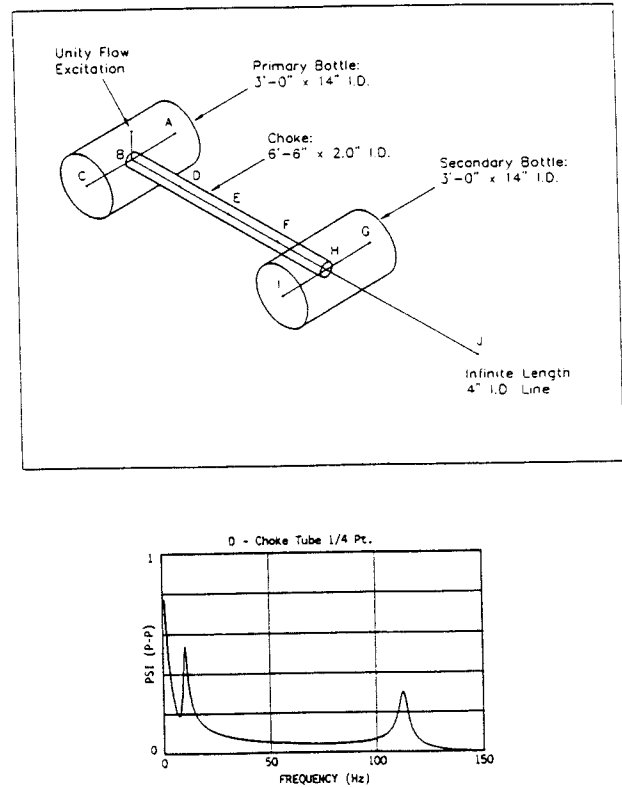

Figure 39. Volume-Choke-Volume Filter (Top) and Frequency Response to Unity Flow Excitation (Bottom) ( $F_H = 10.5$  Hz,  $F_P = 112.5$  Hz).

occur at closed ends. Normally, many different diameters of pipe, complex piping networks with junctions, branches, etc., occur in industrial piping. The acoustic response in these systems are, therefore, much more complex, and are more easily understood using concepts concerning generalized vibrational response of complex structures. Numerous resonance mode shapes occur which take on some distributed characteristics and some lumped characteristics. Actual piping systems have acoustic damping as a result of viscous fluid action (intermolecular shearing), wave transmission and reflections (lack of total reflection at line terminations, junctions, diameter changes), and piping resistance (pipe roughness, restrictions, orifices). Damping of specific acoustic modes may be accomplished by use of resistive elements, such as orifices, which will work most effectively at velocity maxima.

Acoustic Response to Compressor Cylinder Excitation

The cylinder excitation mechanism is a flow modulation consisting of many frequencies, which when injected into the piping, creates response at these various frequencies. The pulsation response spectra are shown in Figure 41 in an infinitely long line (terminated with a characteristic impedance  $Z_c$  excited by a compressor cylinder's discharge flow. The cylinder excitation, which is the same as that used to produce Figure 31, is based on the following assumed data:

- 10 in bore, 2 1/4 in rod
- $L/R = 5$
- 600 rpm
- $P_s = 555$  psia,  $P_D = 1290$  psia
- Natural gas

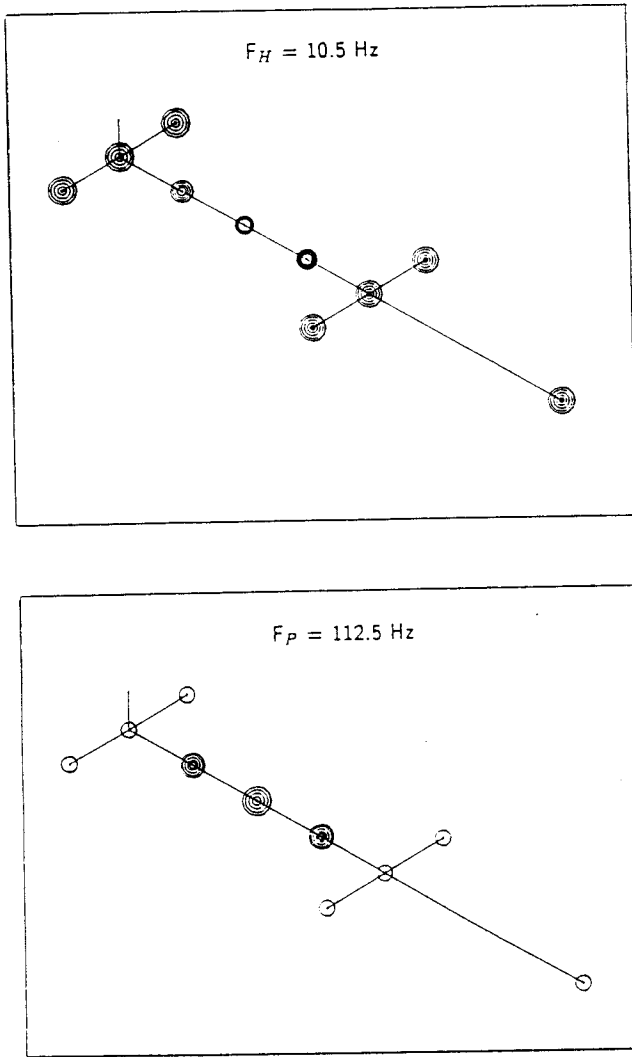

Figure 40. Animation of Low-Mode and Choke Tube (Open-Open) Mode of Volume-Choke-Volume Filter of Figure 39.

The pulsation levels are closely the same at all three test points A, B, and C. Note that the relative amplitudes between the various harmonics is the same for both the excitation (Figure 31) and the pulsation response (Figure 41).

The resulting pulsation spectra are shown in Figure 42 for the pipe configuration of Figure 41, but with the pipe terminated at an open end ( $Z = 0$ ) 30 ft from the piston. Comparing to Figure 41, the addition of the perfectly reflective open end on the right end drastically alters the pulsation amplitudes at the various harmonics. In Figure 41, the 2nd, 4th and 6th orders are greater than the 1st, 3rd, and 5th orders, respectively. In Figure 42, the highest amplitude now occurs at the odd multiples of running speed, and the amplitudes are dependent upon the test point location along the pipe.

The resonant frequencies of this system occur at 10, 30, 50, ... Hz. Therefore, since these resonance frequencies correspond to the excitation frequencies  $1\times, 3\times, 5\times, \dots$ , of the compressor flow excitation, the pulsation amplitudes at these frequencies are amplified. For example, at  $1\times$  running speed ( $10\text{ Hz} = 600\text{ rpm}$ ), the pulsation is increased from three to 80 psi p-p (an amplification factor of approximately 25). Changing the operating speed changes the excitation frequency and the amplitude of the

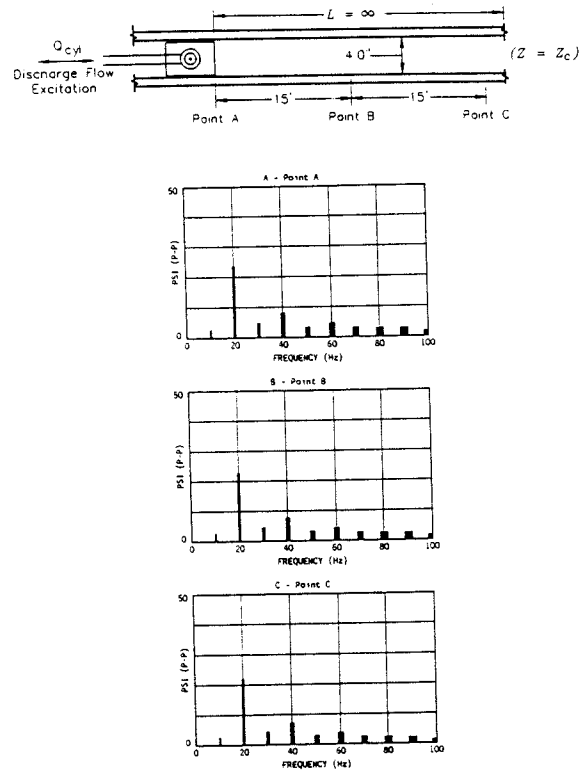

Figure 41. Pulsation Spectra—Cylinder Discharge Excitation into Infinite (Nonresonant) Length Pipe—600 RPM.

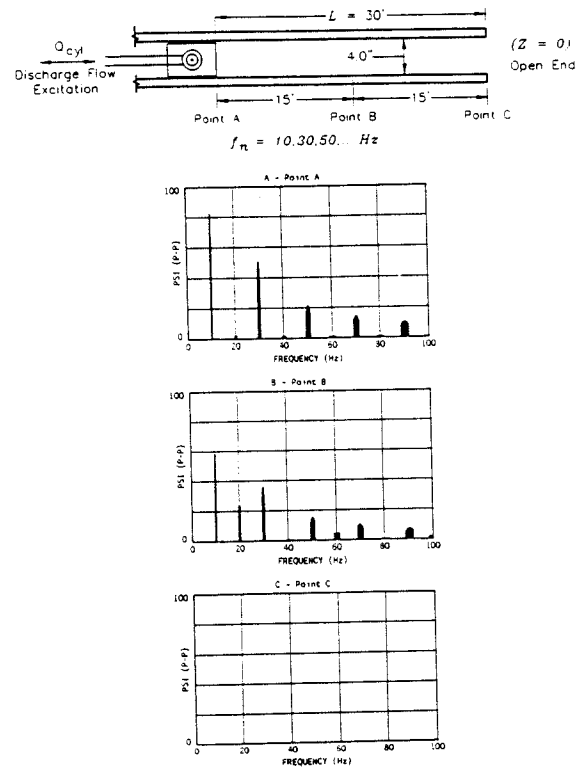

Figure 42. Pulsation Spectra—Cylinder Discharge Excitation into Finite Length, Open End (Resonant) Pipe—600 RPM.

pulsations. Other parameters that affect the acoustic response are the density of the fluid, the velocity of sound, and the

diameter of the piping. Other parameters, such as suction and discharge pressure of the cylinder, stroke, bore, rod diameter, clearance volume, etc., also influence the pulsation amplitudes.

*Acoustical Mechanical Coupling*

Pulsation itself does not produce vibration of the piping system; a point of acoustical-mechanical coupling is necessary to develop a dynamic force, which in turn, produces the vibration.

Several geometric discontinuities are common force—coupling points in industrial piping systems:

- Elbows
- Reducers
- Capped Ends

A general guideline for acceptable pulsation induced forces in piping is 500 lb peak-to-peak for ground level piping that can be adequately supported, and 200 lb peak-to-peak for above ground level piping, such as racks, off-shore platforms, etc. This guideline in turn determines the level of pulsation that can be tolerated at the various points of acoustical mechanical coupling described below.

*Elbows (Bends).* Elbows or bends have differential areas due to outside and inside radii differences, which produce forces in the plane of the elbow. The dynamic force may be calculated for a bend, as is shown in Figure 43. Note that as  $\theta$  becomes larger, the force at elbows becomes lower. Therefore, the number of elbows in a piping system should be minimized to reduce the number of force coupling points, and 45 degree elbows are preferable to 90 degree elbows. Where elbows are required, dynamic restraints (clamps) are desirable near the elbows, since dynamic forces will occur at these locations.

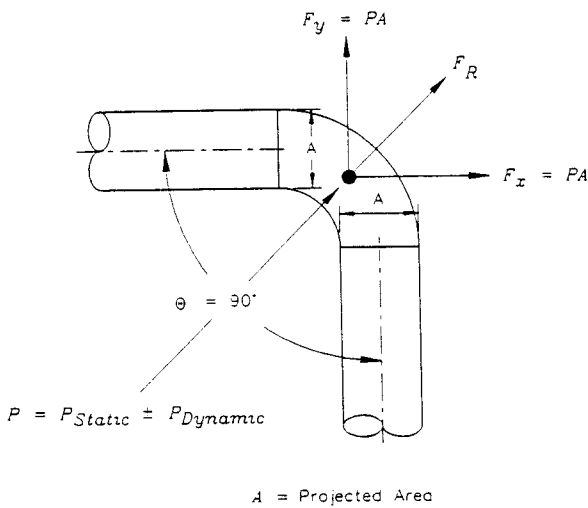

$$F_{Dynamic} = P_{Dynamic} A = F_x = F_y$$

$$F_R = 2 P_{Dynamic} A \cos(\theta/2)$$

Figure 43. Dynamic Force at Elbow.

*Reducers (Area Changes).* The equation for force is shown in Figure 44 acting on the differential area occurring at a reducer. The force,  $F$ , is along the axis of the reducer. Note that since the instantaneous pressure at the reducer varies with time, the force,  $F$ , varies with time.

*Capped Ends (Bottles).* The extreme case of area change is that of a capped end. This condition occurs in all vessels, and is

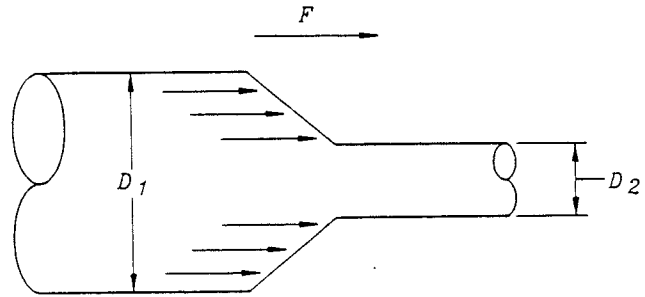

$$F = P_{Dynamic} A = P_{Dynamic} \pi(D_1^2 - D_2^2)/4$$

Figure 44. Dynamic Force at Reducer.

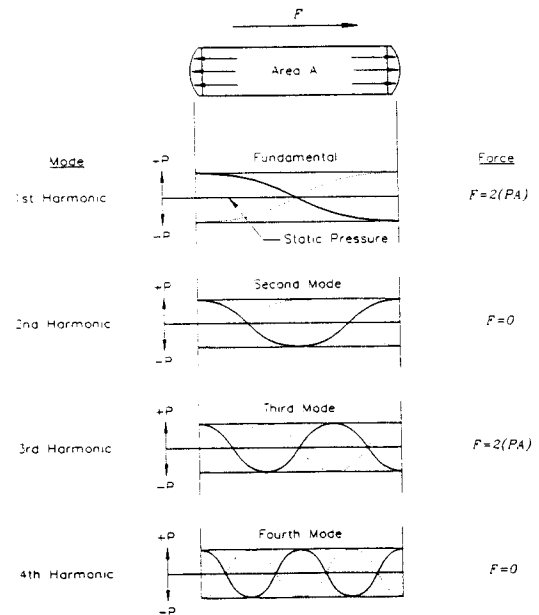
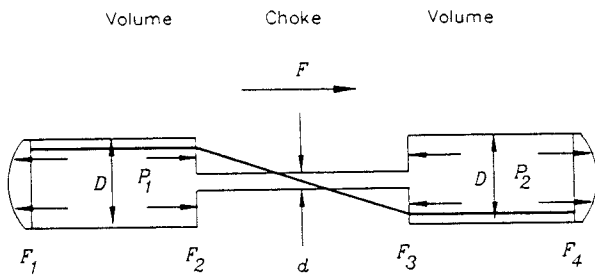

Figure 45. Unbalanced Shaking Force Resulting from Excitation of Closed-Closed Resonance of Pulsation Bottle.

particularly important in surge volumes. The net force acting on a bottle or surge volume is determined by summing the forces acting on each end of a bottle (Figure 45). For the fundamental closed-closed resonance mode discussed earlier, the shaking force acting on the bottle of area  $A$  is  $2AP$  where  $P$  is the dynamic pressure. Therefore, if excitation frequencies occur near the fundamental acoustic resonance mode of a bottle, high shaking force levels can occur since the dynamic pressures are amplified and the instantaneous pressures at the ends are 180 degrees out of phase.

Note that acoustical resonances can occur at the even numbered modes; however, a shaking force is not created, since the phase relationship causes the dynamic forces to cancel.

A similar condition occurs when a volume-choke-volume system is excited at resonance (Figure 46). The dynamic pressures in the two chambers are 180 degrees apart in time. Therefore, a force acting along the axis is produced, which is proportional to the area of the choke. The frequency of this resonance may be controlled by adjusting the bottle and choke sizes (diameters and lengths). This concept is a fundamental tool for the control of pulsation bottle shaking forces.



$$A = \pi D^2/4, \quad \alpha = \pi d^2/4$$

$$F = F_1 + F_2 + F_3 + F_4$$

$$F = -P_1 \alpha + P_2 \alpha = \alpha(P_2 - P_1)$$

$$P_2 = -P_1 (180^\circ \text{ Out of Phase})$$

$$F = 2P_1 \alpha$$

Figure 46. Unbalanced Shaking Force for Volume-Choke-Volume at Resonance of Low Mode.

Control of Pulsation

Pulsation control in compressor piping systems can be accomplished by proper application of the basic acoustic elements of compliance (volume bottles), inductance (chokes), and resistance (pressure drop). These elements can be combined in various manners to achieve pulsation control ranging from attenuation of pulsations to true acoustic filtering. The theory for attenuation and filtering in acoustic fluid systems is similar to that for electrical and mechanical systems. Direct analogies can be made between mechanical, electrical, and acoustical systems. Discussed below are some of the pulsation suppression devices commonly used which range from surge volumes (empty bottles) to acoustic filters (bottles with internals).

Surge Volumes

Surge volumes are often used to attenuate the pulsations produced by compressors. A surge volume is a relatively large, (empty) bottle attached to the suction or the discharge of the compressor. The volume acts as an acoustic compliance (the equivalent of a mechanical flexibility), which can effectively isolate the piping fluid from the flow modulations induced by the compressor. The attenuation characteristics of the surge volume are a function of the volume enclosed by the bottle as well as the expansion ratio of the attached pipe and bottle diameters. For reciprocating compressors, API 618 defines the minimum suction and discharge surge volumes required for pulsation control. The formula for calculation of these minimum volumes is contained in paragraph 3.9.2.2.2 of API 618 (Third Edition, February 1986) [6]. It basically uses 20 times the combined swept volume of the head and crank end of the compressor cylinder, corrected by a square root function for the speed of sound difference between a typical natural gas with a speed of sound of 1400 ft/sec. For example, if the speed of sound were 2800 ft/sec, the recommended volume bottle would be 28.28 times the swept volume.

Economic and mechanical considerations limit the size of surge bottles, and therefore impose practical limits on the degree of overall acoustic attenuation, which can be achieved. Since a surge volume is basically an acoustic "flexibility," it can be sized to reduce pulsations over certain frequency ranges. While

it may reduce the pulsations in a piping system over wide frequency ranges, resonance frequencies of the surge volume length can act as passbands, and excessive shaking forces of the bottle itself can result if the surge volume is not designed properly (Figure 45).

Acoustic Filters

A more effective pulsation control device, compared to the simple surge volume, is the volume-choke-volume filter. This filter consists of two volumes connected by a relatively small diameter pipe (choke tube). The combination of these acoustic elements in this manner produces a low pass filter which attenuates pulsation at frequencies above its cutoff frequency. The dynamic pressure transmission characteristics of the volume-choke-volume filter were demonstrated in Figure 39 as a function of frequency. The resonant peak at frequency,  $f_H$ , is referred to as the Helmholtz frequency of the two-chambered filter, and will amplify pulsations at that frequency. Filters may also have passbands which amplify certain frequencies. These passbands are related to the lengths of certain elements such as choke tube length, chamber length, inlet nozzle length, etc.

Schematics are shown in Figure 47 of possible volume-choke-volume designs along with the equation for the ideal Helmholtz frequency of the filter. The equation is given in Figure 48 of the Helmholtz frequency for a symmetrical filter design. Although this symmetrical design is rarely achieved due to layout considerations, the equation describes the relative effect of the bottle and choke diameters.

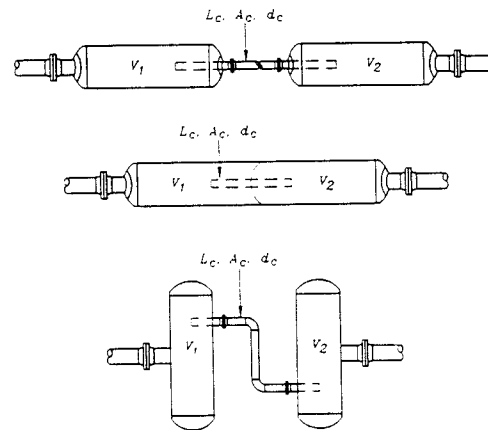

Volume-Choke-Volume Helmholtz Frequency

$$f = \frac{c}{2\pi} \sqrt{\frac{A_c}{L_c'} \left( \frac{1}{V_1} + \frac{1}{V_2} \right)}$$

- where  $f$  = frequency (Hz)
- $c$  = speed of sound ( $\frac{ft}{sec}$ )
- $A_c$  = area of choke tube ( $ft^2$ )
- $L_c$  = length of choke tube (ft)
- $L_c' = L_c + 6d$  (ft)
- $d_c$  = choke diameter (ft)
- $V_1$  = volume of primary bottle ( $ft^3$ )
- $V_2$  = volume of secondary bottle ( $ft^3$ )

Figure 47. Equation for (Nonsymmetrical) Volume-Choke-Volume Helmholtz Frequency.

Normal design procedure for low pass filters is to design the Helmholtz frequency below the lowest pulsation frequency to be attenuated. Effective pulsation reduction can be achieved for frequencies above approximately twice the Helmholtz frequen-

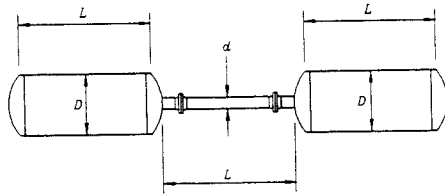

Symmetrical Volume-Choke-Volume Helmholtz Frequency

$$f = \frac{c}{\sqrt{2\pi L}} \left( \frac{d}{D} \right)$$

where  $f$  = frequency (Hz)  
 $c$  = speed of sound ( $\frac{\text{ft}}{\text{sec}}$ )  
 $d$  = choke diameter (ft)  
 $D$  = diameter of each bottle (ft)  
 $L$  = acoustic length of bottles and choke (ft)

Figure 48. Equation for Symmetrical Volume-Choke-Volume Helmholtz Frequency.

cy and even closer in some systems. In many installations, it is necessary to place the Helmholtz in between excitation orders, generally the first and second order, which is difficult to accomplish in variable speed machines.

**Orifice Plates**

Orifice plates are used at various locations in piping systems to reduce acoustical response at resonant frequencies. The orifice plate creates a pressure drop that serves as an acoustic resistance to dampen out the resonance. For the most effective damping, the orifice plate should be placed as close to the location of the maximum particle velocity.

For example, acoustic resonances occur in the nozzle which connects a bottle to a reciprocating compressor cylinder flange. The nozzle in conjunction with the cylinder internal flow passages creates a resonance (similar to a quarter wave), wherein the bottle acts as an open end and the surface of the piston (when the valves are open) acts as the closed end. To attenuate this resonance, an orifice plate may be installed at the nozzle-bottle junction that is the point of maximum particle velocity; however, locating the orifice at the cylinder flange is usually effective, as can be shown through simulation.

**Comparison of Pulsation Suppression Devices in Gas Systems**

The type of pulsation suppression device required depends on the degree of pulsation control desired. In certain cases, a surge volume may provide adequate attenuation of pulsations. However, for maximum attenuation over a wider frequency range, an acoustic filter should be designed. Even with an acoustic filter, several levels of pulsation control are possible depending on the size of the elements (bottle, choke) used. Because of the need for bottle internals or a two bottle design to achieve the acoustic filter, the cost of these devices is normally higher than that of a single surge volume. The actual size of the surge volumes or filters depends on the speed of the compressor or pump, the stage pressure ratio, the thermophysical properties of the fluid, and the geometry of the piping system.

In order to illustrate the relative effect of the different types of pulsation devices, several devices were analyzed using the digital acoustical simulation program. The discharge piping of a typical compressor cylinder was assumed in conjunction with various size surge volumes and acoustic filters. A case assuming no pulsation control device in the piping system was also analyzed. The compressor cylinder simulated has a 9.25 in bore

with a 6.0 in stroke and an operating speed range of 700 to 1000 rpm. The suction pressure is 267 psia, and the discharge pressure is 567 psia. To eliminate the effect of piping acoustic resonance, the attached piping is assumed to be infinite length. Note that this assumption ignores the interaction of the compressor/bottle with the attached piping, and therefore compares only the relative effects of the various bottles themselves.

The pulsation control devices considered are listed below, with the results of the analyses shown in Figures 49, 50, and 51.

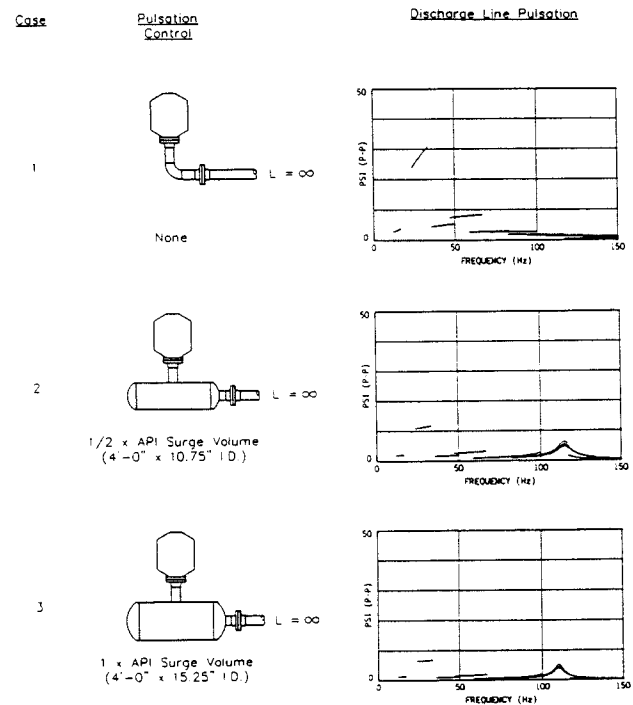

Figure 49. Comparison of Pulsation Control Devices for (Single Cylinder) Compressor Discharge Piping System—1/2 and 1 x API Surge Volume.

Case 1: No pulsation control.

Case 2: A surge volume with one-half the volume required by API 618.

Case 3: A surge volume with the full API 618 recommended volume.

Case 4: API 618 surge volume with an orifice plate at the bottle inlet (cylinder discharge) flange.

Case 5: A volume-choke-volume acoustic filter with its Helmholtz or cut-off frequency near 4 times running speed (50 Hz).

Case 6: A volume-choke-volume acoustic filter. The Helmholtz or cut-off frequency of this filter is approximately 22 Hz (between 1x and 2x running speed).

Case 7: A volume-choke-volume acoustic filter with the Helmholtz frequency tuned between 1x and 2x running speed (22 Hz). The larger bottle and choke tube in this design result in the same Helmholtz frequency as Case 6, but with less pressure drop.

Case 8: A volume-choke-volume acoustic filter. The Helmholtz or cut-off frequency of this filter is approximately 9 Hz (below 1x running speed).

Frequency spectra of the pulsation in the discharge pipe (downstream of the pulsation suppression device) are presented in a graphical data format for each case.

Each of the frequency spectra plots contain multiple curves representing frequency response at each individual harmonic of



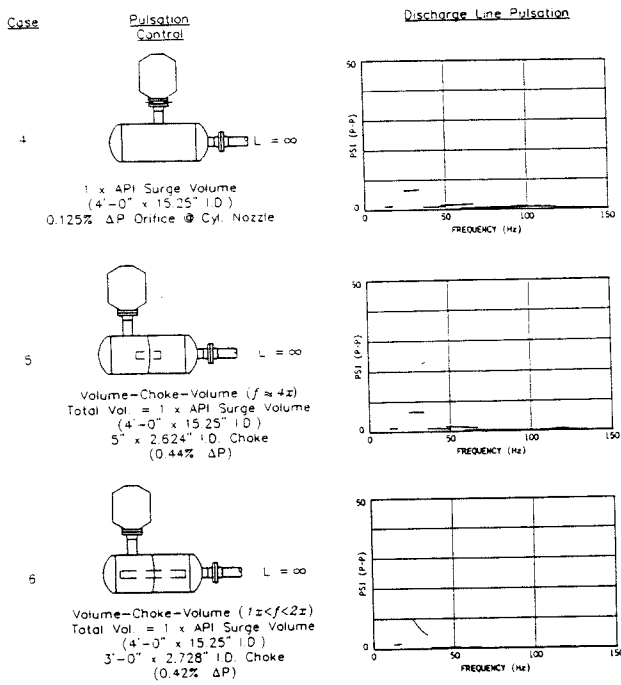

Figure 50. Comparison of Pulsation Control Devices for (Single Cylinder) Compressor Discharge Piping System—Effect of Orifice Plates and VCV Filter.

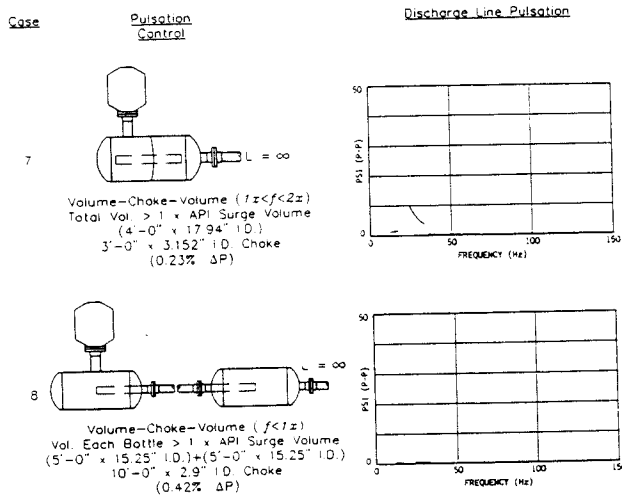

Figure 51. Comparison of Pulsation Control Devices for (Single Cylinder) Compressor Discharge Piping System—Effect of Helmholtz Filter Frequency.

compressor speed. The amplitude of pulsation in psi p-p of each harmonic is plotted vs frequency in Hertz for the full speed range of the simulation. For example, for a compressor speed range of 700 to 1000 rpm, the first harmonic would sweep the 11.67 to 16.67 Hz range, the second harmonic would sweep the 23.34 to 33.33 Hz range, etc. These data formats are important for evaluating the actual predicted pulsation amplitudes and frequencies of individual harmonic components. A knowledge of both amplitude and frequency is important in evaluating the acceptability of piping designs from a vibration standpoint.

For Case 1, in which no pulsation control is assumed, a high response is predicted at the second harmonic of running speed (referred to as 2x running speed—from 23.3 to 33.3 Hz). The

simulation predicts a maximum amplitude at 2x running speed of approximately 32 psi p-p. The high amplitude pulsation at 2x running speed is expected, because the cylinder is operating in a double acting mode. This causes two pulses to be generated each cycle. Note that the actual pulsation trace in the line measured with a dynamic pressure transducer would be some combination of all of the harmonics of running speed.

In Case 2, a surge volume with one-half the volume recommended by API 618 is connected to the discharge flange of the cylinder. The peak pulsation at 2x running speed is lowered from 32 psi p-p in Case 1 to approximately 12 psi p-p with the surge volume. However, note that a new response is predicted at 115 Hz with a maximum amplitude of approximately 6.0 psi p-p. This response is a result of the “nozzle” resonance between the cylinder and the bottle. Pulsation is transmitted through the surge volume into the discharge line at this frequency. Note that the amplitudes are much higher at the cylinder valves at this frequency than at the piping test point.

In Case 3, a larger surge volume with the volume recommended by API 618 is connected to the discharge flange of the cylinder. In this case, the maximum predicted pulsation at 2x running speed is lowered to approximately 8.0 psi p-p. The nozzle resonance still occurs, but near 110 Hz and with a maximum predicted amplitude of 6.0 psi p-p.

Case 4 is identical to Case 3, except that an orifice plate has been added to the cylinder discharge flange. The orifice plate has a pressure drop of 0.71 psi (0.125 percent of line pressure). In comparing Case 3 to Case 4, note that the addition of the orifice plate did not affect the predicted amplitude at 2x running speed. However, the predicted amplitude at 110 Hz (the nozzle resonance) is reduced to below 2.0 psi p-p.

Case 5 represents a volume-choke-volume filter with the Helmholtz frequency set to approximately 60 Hz (4x running speed). Note that the total volume of the filter (both chambers) is equivalent to the API 618 recommended surge volume used in Cases 3 and 4. This filter could be created by adding a baffle to divide the API 618 surge volume into two chambers and connecting them with a choke tube through the baffle as shown. The pressure drop through the choke tube is approximately 2.5 psi (0.44 percent). The pulsation spectra for Case 5 looks almost identical to that of Case 4. The effect of the choke tube is to attenuate pulsations above the Helmholtz frequency (60 Hz). The nozzle resonance near 110 Hz (See Case 3) is attenuated with the filter; however, the pulsation at 2x running speed is unaffected. In comparing Case 4 to Case 5, essentially the same pulsation control can be obtained using an orifice plate having a pressure drop of 0.125 percent of line pressure as can be obtained by adding a choke tube with 2.5 psi pressure drop.

Case 6 represents a volume-choke-volume filter (using a total volume equal to the API 618 recommended volume) with a Helmholtz frequency which has been set to approximately 22 Hz (between 1x and 2x running speed). This is accomplished by using a longer choke tube with a slightly larger diameter. The resulting pressure drop through this choke tube is 2.4 psi (0.42 degree), which is approximately the same as in Case 5. Note that the maximum predicted response at 2x running speed actually increases in this case to approximately 11 psi p-p (compared to Cases 3, 4, and 5). Note also that the shape of the harmonic curve has changed, with the maximum amplitude occurring at the lowest frequency (approximately 23.3 Hz, corresponding to 700 rpm compressor speed). This increase in predicted pulsation at 2x running speed is caused by its proximity to the Helmholtz frequency of the filter. Pulsations greater than this frequency are generally attenuated, but pulsations near this frequency can be amplified. Note, however, that the predicted pulsation at 2x is still less than that predicted in Case 1, with no pulsation control.

Case 7 shows a volume-choke-volume filter where the Helmholtz frequency has, as in Case 6, been tuned between 1x and 2x running speed. However, in this case, the bottle volume and the choke diameter have been increased. This results in practically the same attenuation characteristics, but only requires a pressure drop of 1.3 psi (0.23 percent of line pressure) through the choke tube.

Finally, Case 8 represents a volume-choke-volume filter with a Helmholtz frequency that has been set to approximately 9 Hz (below 1x running speed). This is accomplished with large volumes and longer choke tubes. The filter can be built as one large bottle with a baffle and choke tube, or it can be built using primary and secondary bottles, with the choke tube connecting them as shown in the schematic in Figure 47. The pressure drop through the choke tube is again 2.4 psi (0.42 percent) for this case. The predicted pulsations are significantly attenuated at all harmonics of running speed. No harmonic is predicted to have pulsation levels greater than 1.0 psi.

*Comparison of Pulsation Suppression Devices in Liquid Systems*

The theory of pulsation control in liquid systems is identical to that in gas compressor systems [3, 14, 15, 16, 17, 18, 19]. Surge volumes, acoustic filters, and orifice plates are all effective pulsation control devices when utilized properly. The mechanical analogies of flexibility, mass, and damping used to describe how the devices work are identical to those discussed previously.

One commonly used device that is very effective in pump systems is referred to as the volume-choke all-liquid filter (Figure 52). This device utilizes a single volume (bottle) near the pump flange, and a choke tube, which may be internal or external to the bottle. The choke tube connects directly to the larger main feed or discharge line through a reducer. This device does not result in as sharp a cutoff of higher frequency components as the volume-choke-volume filter, but is effective in pump systems since, compared to compressor systems, higher pressure drop may be tolerated in positive displacement pumps. This allows smaller choke tubes to be utilized, increasing the filtering/isolation effect.

Three cases of pulsation control are compared in Figure 53 for a triplex oil pump discharging into an infinite line. The three cases are:

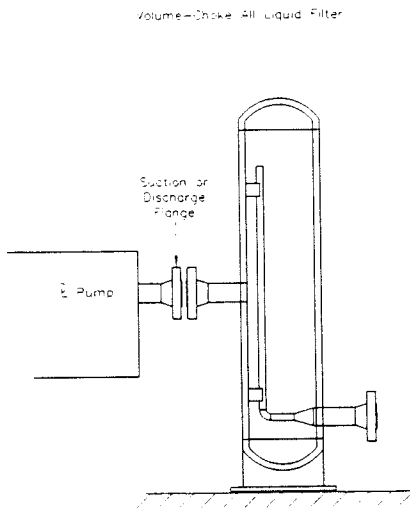

Figure 52. Volume-Choke All-Liquid Filter for Control of Pump Piping Pulsation.

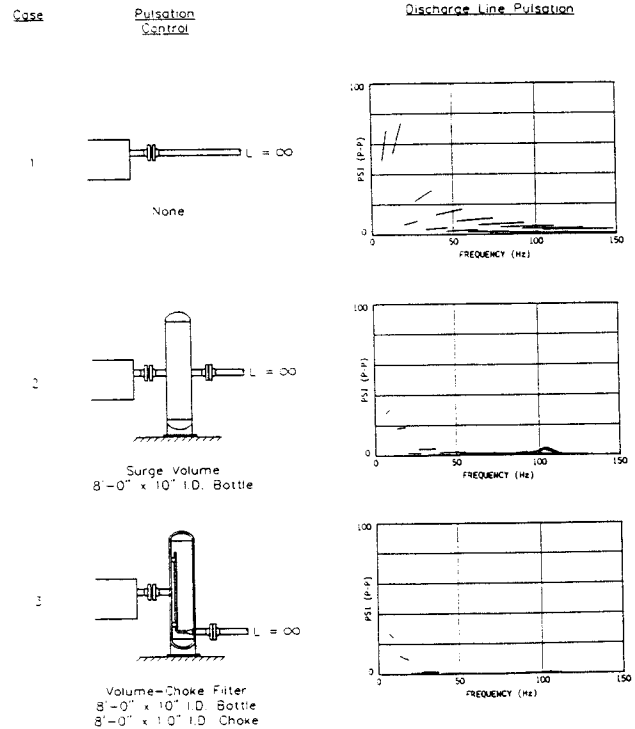

Figure 53. Comparison of Pulsation Control Devices for Triplex Pump Discharge (130 to 195 rpm).

- Case 1: No pulsation control.
- Case 2: Single surge volume (all-liquid).
- Case 3: Volume-choke all-liquid filter.

The addition of the bottle reduces the pulsation levels considerably over the entire frequency range. Addition of the choke tube to the same bottle reduces the amplitudes of the pulsation at higher frequencies.

Some typical types of gas-charged devices often used on reciprocating pumps are shown in Figure 54. The devices are commonly called accumulators or dampeners, and have the beneficial characteristics of surge volumes. These accumulators are made in a variety of configurations. The bladder or diaphragm types (b, c, and d) are commonly used in liquid pump installations to reduce pulsation in both suction and discharge piping. Type a has no bladder to prevent absorption of the gas into the liquid. The effectiveness of these accumulators can be reduced by bladder stiffness and restriction of bladder expansion and compression by constraining cages, mandrels, etc. Accumulators should be tuned for maximum effectiveness in a system. Although manufacturers generally specify a particular accumulator on the basis of pump size or capacity, the effectiveness of the accumulator is dependent upon many factors that cannot be evaluated without acoustical simulation techniques.

These devices attempt to take advantage of the fact that the gas offers an acoustical compliance characteristic which has an effective volume in terms of the liquid of:

$$V' = \frac{K_{\text{liquid}} V_{\text{gas}}}{K_{\text{gas}}} = \frac{(\rho c^2)_{\text{liquid}} V_{\text{gas}}}{(\rho c^2)_{\text{gas}}}$$

- where K = bulk modulus (psi)
- c = speed of sound (ft/sec)
- ρ = density (lb/ft<sup>3</sup>)

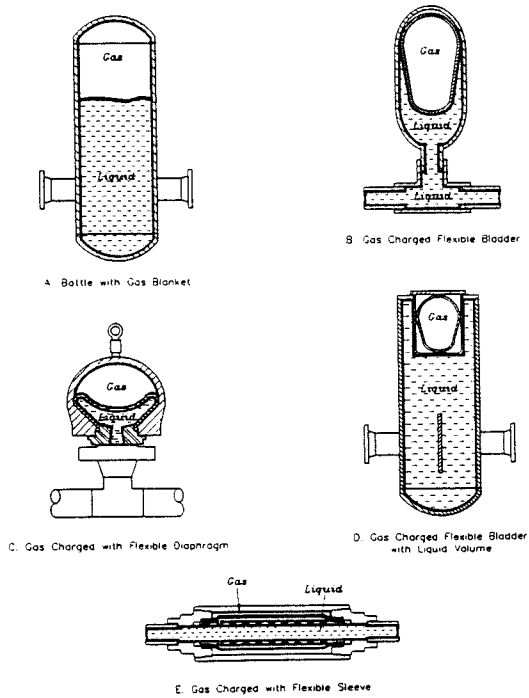

Figure 54. Common Types of Pulsation Accumulators (Dampeners) Used in Liquid Systems.

$V$  = volume ( $\text{ft}^3$ )

$V'$  = equivalent liquid volume

Unfortunately, the performance of these devices is degraded by:

- Neck inertance (restriction) effects which reduce compliance effects
- Bladder stiffness effects
- Absorption of gas in nonbladder devices
- Nonlinear effects, such as bladder restriction caused by physical dimensions of device (cases, mandrels)
- Complete failure of bladder as well as permeability to certain liquids
- Sensitivity to pressure (volume and bulk modulus change)

These characteristics make their performance more difficult to predict than the all-liquid type devices.

Gas charged devices are also used to control "water-hammer" for transient flow problems in liquid systems.

#### Acoustic Simulation of Compressor and Pump Systems

An understanding of the overall characteristics of the acoustic resonant frequencies is important in order to make effective and efficient design decisions regarding the control of pulsation in the piping. One of the most important tools available to this end is the ability to display pulsation spectra and acoustic mode shapes of actual systems. Examples of simulation of actual systems are presented here.

#### Hydrogen Compressor Suction Piping System

The simulation of this system serves as an example of the type of data generated during an acoustic simulation, as well as the effectiveness of orifice plates in certain systems.

The piping model diagram shown in Figure 55 is of the suction system of two parallel Hydrogen compressors, each consisting of a single cylinder [11]. Pulsation test points are documented on the diagram. Test points are shown at each bottle, each suction riser, midway between the two units in the header, in the header near the scrubber, and in the scrubber itself.

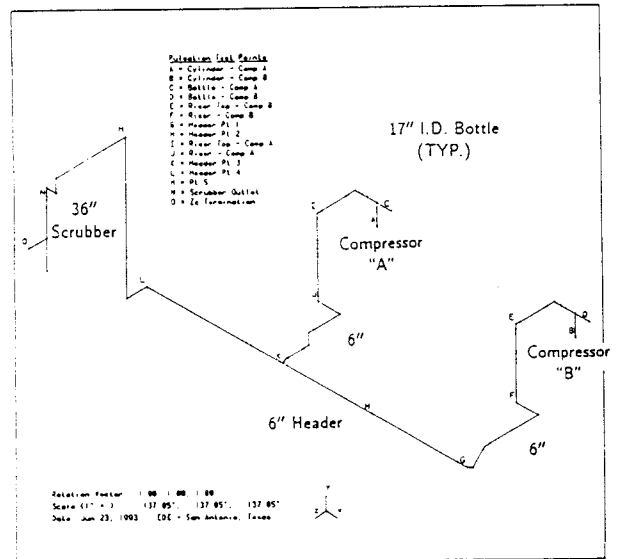

Figure 55. Suction Piping System of Two  $H_2$  Compressors.

The upper graph in Figure 56 gives the pulsation spectrum at the cylinder flange test point of compressor A for single acting operation of the compressor cylinders. Since the compressors run at 450 rpm, the fundamental excitation frequency is 7.5 Hz, and high pulsation levels (120 psi p-p) occur at both compressors near this frequency. The simulation considers a speed range ( $\pm 10$  percent), so that response peaks can be identified. Note that the shape of the response curve indicates a peak response or resonance just above 7.5 Hz.

The passive frequency response (middle graph—Figure 56) shows various resonant frequencies, with a dominant response at 8.15 Hz. Animation showing the relative amplitude and phase relationships of the 8.15 Hz resonance (Figure 57), indicates that the pulsation amplitudes are (180 degrees) out of phase at the bottles of the two compressors, with a pressure node near the header midway point between the compressors. These mode shape data give insight into effective locations for orifice placement, since orifice plates are most effective when located at velocity maximums.

Based on the simulation results, it can be determined that orifice plates would be most effective when placed in the suction lead lines or in the header of the two compressors as opposed to locating one at the scrubber vessel outlet flange. The lower graph of Figure 56 shows simulation results with orifice plates installed at the suction bottle inlet flange of each compressor. Pulsation levels at  $1\times$  running speed were reduced by a factor of approximately 10. (Note the y-axes are auto-scaled, so that the scales of the upper and lower graphs are different.)

#### Suction Piping of Four Natural Gas Compressors

The computer generated piping model diagram of the suction piping is shown in Figure 58 of four six-cylinder, single-stage compressors in a common header [11]. The passive frequency

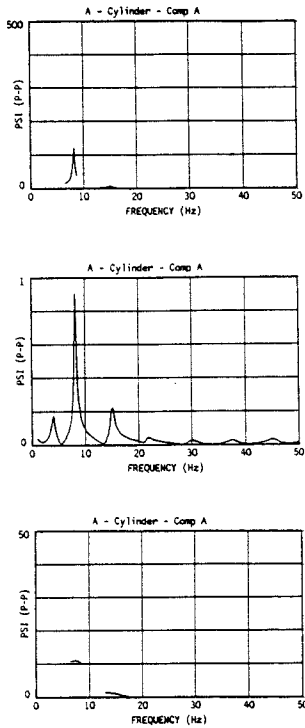

Figure 56. Pulsation Spectra at Compressor A Cylinder Flange for Two, 450 RPM, Single Acting H<sub>2</sub> Compressors/Suction Piping System Predicted Pulsation at 1 × = 120 PSI P-P at Cylinders (Top), Passive Frequency Response—Resonance at 8.15 Hz (Middle), and Orifices Installed at Suction Bottle Inlets (Bottom).

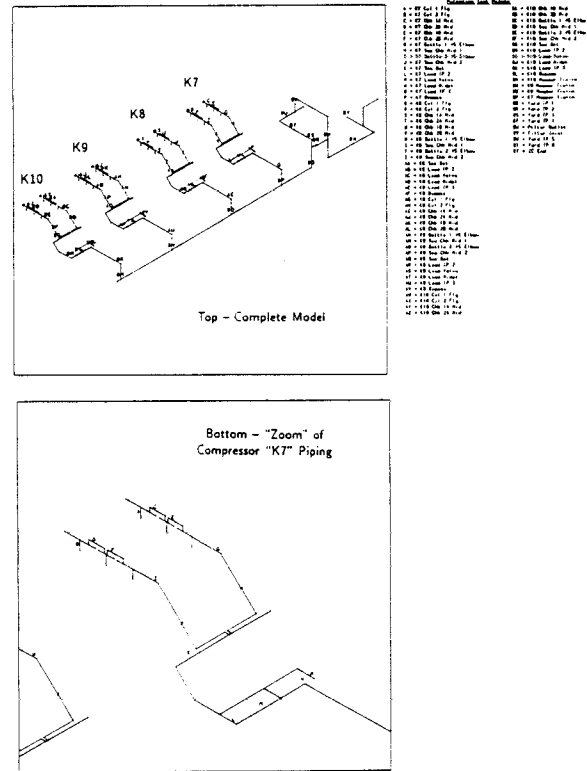

Figure 58. Suction Piping Model of Four Natural Gas Compressors.

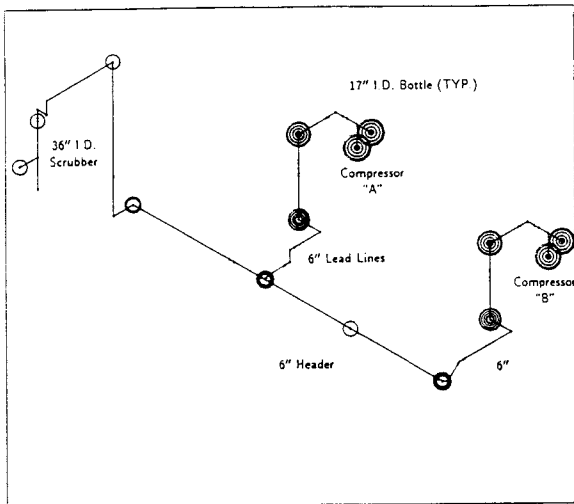

Figure 57. H<sub>2</sub> Compressor Suction System—Animated Mode Shape at 8.15 Hz.

response (spectrum) is shown in Figure 59 at the cylinder flange of the far right compressor due to a flow excitation at one cylinder of the same compressor. A representation of the animation of the lowest acoustic natural frequency near 1.7 Hz is also illustrated. The mode involves oscillatory flow of the header between the two end compressors such that the maximum pressure modulation occurs at the end compressors. Note that the pulsation levels are low in the header itself. Each of the peak response frequencies shown in the passive analysis has a char-

Pulsation Spectra

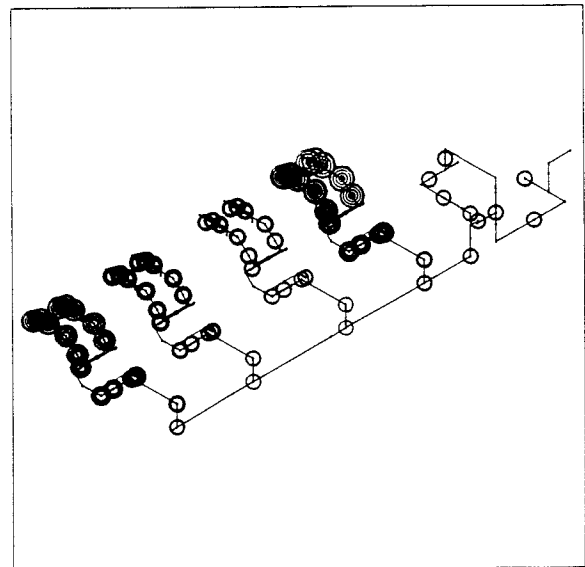
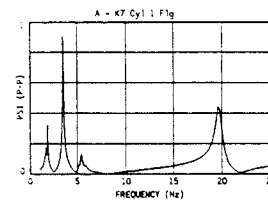

Figure 59. Passive Frequency Response (Top) and Animation of Lowest Acoustic Natural Frequency at 1.7 Hz (Bottom).

acteristic acoustical mode shape which can be demonstrated in a similar manner. The second mode near 1.9 Hz involves oscillatory flow of the header portion between the two compressors on the far left. The third modes near 3.5 Hz and 5.4 Hz are associated with the primary and secondary bottles, and the mode near 20 Hz is associated with the frequencies of the primary bottle itself.

*Discharge Piping of a Triplex Pump System*

The piping model diagram for the discharge system is shown in Figure 60 of four triplex oil pumps [3]. Each pump has a gas-charged bladder type device installed near its discharge flange. The four pumps are tied to a common header, with one end capped, and the other terminated with a characteristics impedance (infinite length line). A zoom of the piping model near pump 1 is shown in Figure 61.

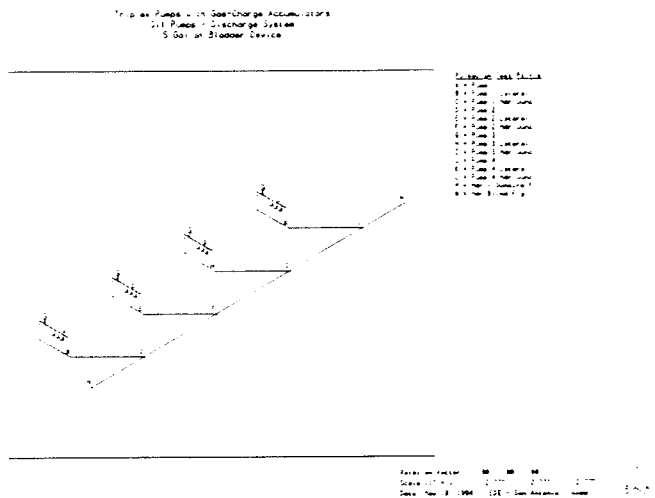

Figure 60. Piping Model Diagram for Discharge System of Four Triplex Pumps.

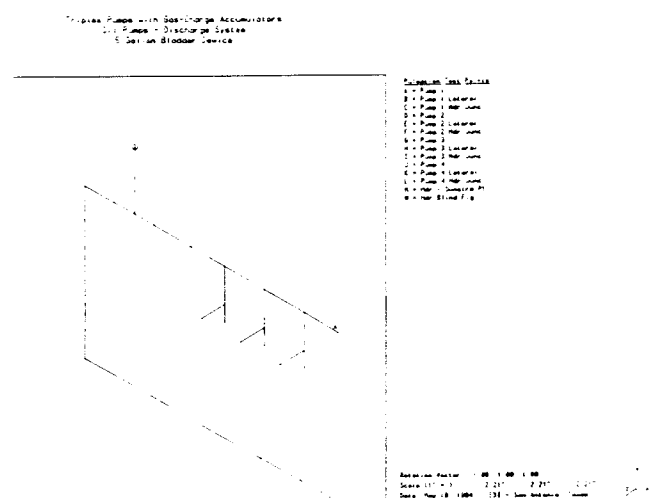

Figure 61. Piping Model Diagram for Discharge System of Four Triplex Pumps—Zoom of Pump No. 1.

The simulation results for the system assuming 2.5 gallon bladder devices are given in Figure 62. The pulsation levels are predicted to be on the order of 50 psi p-p, which are higher than desirable. In an effort to reduce the pulsations, the bladder type of pulsation device was changed to a 5 gallon device. The results

of using the 5.0 gallon device are shown in Figure 62. It can be seen that the larger bladder volume actually caused the pulsations at the cylinder to increase from approximately 30 psi p-p at the plunger frequency to 140 psi p-p, and at the lateral from 16 psi to 90 psi. The general rule of thumb would be that the pulsations should be reduced when the large gas volume is used. The passive analysis (Figure 63) for the two bladder devices demonstrates the reason why the smaller device achieved lower pulsations in the pump system. The larger gas volume actually caused a resonance to shift to the plunger frequency, which amplified the pulsations.

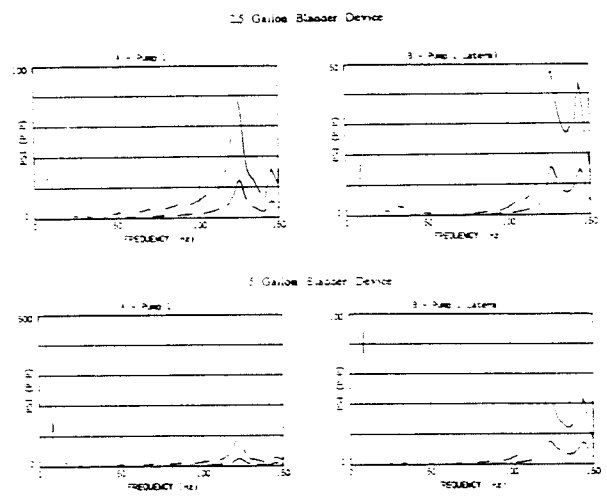

Figure 62. Pulsation Spectra for Triplex Pump Discharge System—2.5 Gallon Bladder Device on Each Pump (Top), 5.0 Gallon Bladder Device on Each Pump (Bottom)

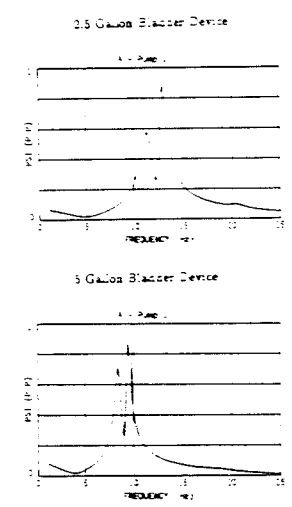

Figure 63. Comparison of Passive Frequency Response at Pump No. 1—2.5 Gallon Bladder Device (Top), 5.0 Gallon Bladder Device (Bottom).

**CONCLUSIONS**

The vibration problems commonly encountered in plants with reciprocating machinery have been presented. The procedures for calculating the natural frequencies of piping spans has been presented as well as detailed information to help with the understanding as to the causes of acoustically induced pulsation shaking forces. The methods of control of pulsations has been

demonstrated as well as current technology for analyzing pulsations. Criteria for judging the acceptability of vibrations in reciprocating plants has been presented. Some of the general design guidelines used in the design stage and for troubleshooting are given in the following section.

#### *General Guidelines for Piping Systems*

- The piping span mechanical natural frequency should not be coincident with any excitation frequency. The mechanical natural frequency should be above the highest excitation frequency by a factor of two, if possible. The individual piping spans should be designed to have a mechanical natural frequency of at least 50 Hz, if the excitation frequencies are not known.

- Pipe supports and clamps should be installed on one side of each bend, at all heavy weights, and at all piping discontinuities.

- The support and clamp stiffness should be adequate to restrain the shaking forces in the piping to the desired amplitudes and should be approximately twice basic span stiffness to enforce a node at the support location.

- Vents, drains, bypass, and instrument piping should be braced to the main pipe to eliminate relative vibrations between the small-bore piping and the main pipe.

- Restraints, supports, or gussets should not be directly welded to pressure vessels or piping unless they are subjected to the appropriate heat treatment.

- Pipe guides with clearance that are used to allow thermal expansion should not be used to control piping vibrations.

- To resist vibration, piping clamps should have contact with the pipe over at least 180 degrees of the circumference with a viscoelastic type material between the clamp and the pipe to improve the contact.

- Do not use unreinforced branch connections in compressor manifold systems. High displacements can exist in these systems, which transfer the stresses to the weld.

- Use straps and wedges on bottles underneath compressor cylinders to increase damping and resistance to shaking forces along the bottle axis. The straps and wedges should be tightened after the unit has reached operating temperature to minimize thermal expansion stresses.

- Digital and analog techniques are available to calculate the acoustical natural frequencies and the expected pulsation amplitudes in piping systems. For critical applications and to ensure safety of the plant, it is recommended that the systems be analyzed in the design stage.

- In designing pulsation bottles for reciprocating compressors, it is desirable to use volume-choke-volume pulsation filters that filter the pulsation levels transmitted to the system piping. It is "penny-wise and pound foolish" to try and get by with one less bottle in the filter system to save money. Excessive vibration and stress levels often result.

- In designing pulsation control devices for reciprocating pumps, a volume-choke acoustical filter system is usually effective in controlling the pulsations in the piping and should be placed as close as possible to the pump flange.

- Pulsation control devices which use a gall-filled bladder must be properly charged. Small changes in the charge pressure can affect the acoustical pulsations, shaking forces, NPSHA, cavitation, etc.

- Orifice plates can be very effective in attenuating specific acoustical natural frequencies if they are located near the point maximum acoustical velocity.

#### REFERENCES

1. Wachel, J. C. and Szenasi, F. R., "Torsional Vibration Analysis," *Proceedings of the Twenty-Second Turbomachinery Symposium*, The Turbomachinery Laboratory, Texas A&M University, College Station, Texas (1993).
2. Wachel, J. C., Atkins, K. E., and Morton, S. J., "Piping Vibration Analysis," *Proceedings of the Nineteenth Turbomachinery Symposium*, The Turbomachinery Laboratory, Texas A&M University, College Station, Texas (1990).
3. Wachel, J. C., Tison, J. D., et. al., "Vibrations in Reciprocating Machinery and Piping," Engineering Dynamics Incorporated Report 41450 (1993).
4. Wachel, J. C., "Piping Vibration and Stress," *Proceedings of the Machinery Vibration Monitoring and Analysis*, Vibration Institute (April 1981).
5. Wachel, J. C. and Smith, D. R., "Vibration Troubleshooting of Existing Piping Systems," Engineering Dynamics Inc. Seminar Presentation (July 1991).
6. "Reciprocating Compressors for General Refinery Services," API Standard 618, American Petroleum Institute, Washington, D.C. (February 1986).
7. Olson, D. E., "Piping Vibration Experience in Power Plants," Pressure Vessel and Piping Technology, A Decade of Progress, Book No. H00330, ASME (1985).
8. "Preoperational and Initial Startup Vibration Testing of Nuclear Power Plant Piping Systems," ANSI/ASME Operations & Maintenance Standards/Guides Part-3, ASME, New York, New York (1990).
9. "Nuclear Power Piping," USAS B31.7—1969 ASME Code (1969).
10. Wachel, J. C., "Field Investigation of Piping System for Vibration—Induced Stress and Failures," Pressure Vessel and Piping Conference, ASME Bound Volume No. H00219 (June 1982).
11. Tison, J. D. and Atkins, K. E., "Acoustical and Mechanical Design Concepts—Understanding and Controlling Pulsation," 8th Annual Reciprocating Machinery Conference, Denver, Colorado (1993).
12. Wachel, J. C., Szenasi, F. R., and Baldwin, R. M., "Dynamic Vibrations of Stationary Engines," ASME Paper 78-DGP-1 (1978).
13. Atkins, K. E. and Price, S. M., "Evaluation of Reciprocating Compressor Foundations Using Vibration Measurements," PCRC 7th Annual Reciprocating Machinery Conference, Denver, Colorado (September 1992).
14. "Positive Displacement Pumps, Reciprocating," API Standard 674, American Petroleum Institute, Washington, D.C. (December 1987).
15. Blevins, R. A., *Flow-Induced Vibration*, New York, New York: Van Nostrand Reinhold (1977).
16. Wachel, J. C., Szenasi, F. R., and Denison, S. C., "Analysis of Vibration and Failure Problems in Reciprocating Triplex Pumps for Oil Pipelines," ASME Paper 85-PET-10 (1985).
17. Wachel, J. C., Szenasi, F. R., and Denison, S. C., "Acoustical Analyses Solve Vibration, Failures in Recip Pumps," *Oil & Gas Journal*, pp. 60-72 (August 11, 1986).
18. Wachel, J. C. and Price, S. M., "Understanding How Pulsation Accumulators Work," Pipeline Engineering Symposium, PD-Vol. 14, Book No. 100256 (1988).

19. Wachel, J. C., Tison, J. D., and Price, S. M., "The Effect of Pulsations on Cavitation in Reciprocating Pump Systems," ASME Paper 89-Pet-10 (1989).